



Converting Catalog 2016

Revolutionizing the Converting Industry with Quality Product Solutions



NEW PRODUCTS
in 2016
see pages: 20, 22, & 23

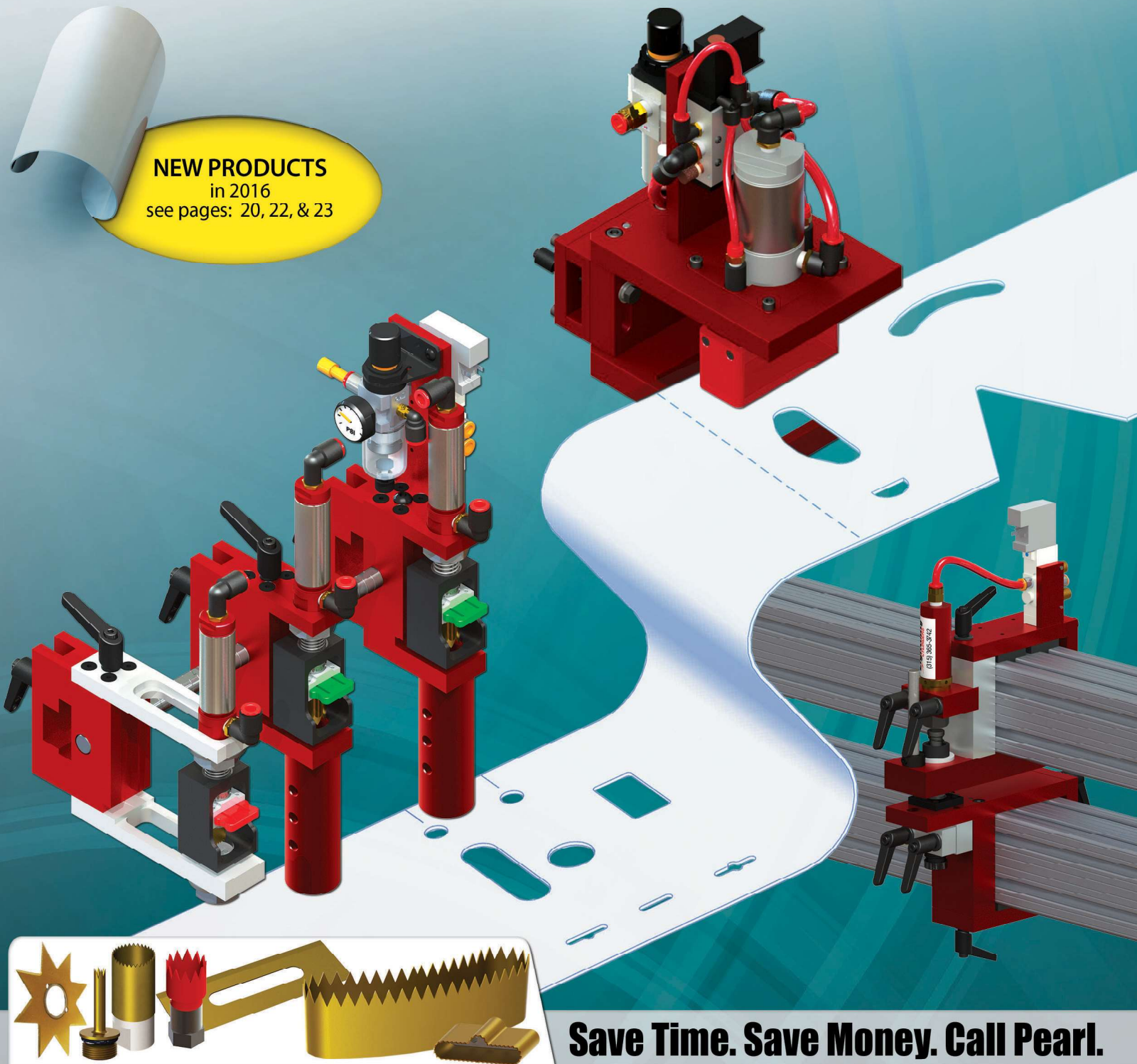

Save Time. Save Money. Call Pearl.

13297 Seneca Street, Savannah, NY 13146 • ph: 315-365-3742 • sales@pearltechinc.com • www.pearltechinc.com

Table of Contents

- page 3 - 1 Piece vs. 2 Piece Designs / Punches for Every Application
- page 4 - 1 Piece Tru-Kote Punches / Tear Notch Punches / Retrofit Punches for Totani
- page 5 - Piranha and Barracuda Punches
- page 6 - Tru-Kote Punches / Shark Punches
- page 7 - Tru-Kote Punch Adapters / Slug Ejectors
- page 8 - Handle Hole Punches / Hanger Hole Punches
- page 9 - Plastic Punches / Plastic Punch Adapters
- page 10 - Repairable Air Cylinders / Non-Repairable Air Cylinders
- page 11 - Wicket Hub Assemblies / Retrofit Arms
- page 12 - Lightning Wicket Attachment
- page 13 - Lightning Wicket Punches / Kleen-Cut Punches
- page 14 - Sealer Attachment / Spin Punch Attachment
- page 15 - Zero Clearance Punching / Crimper Attachment
- page 16 - The Flex Concept / Flex 1
- page 17 - Flex 2
- page 18 - Flex 3
- page 19 - Flex 4
- page 20 - High Definition Flex / Patch Handle Attachment
- page 21 - Drawstring Swipe Cut / Pivot Punch Attachment
- page 22 - C-Frame / Cross Web Ball & Die
- page 23 - 2-Piece Plungers / Ball & Die Punch Retrofits for Park Air
- page 24 - Cross Rail Perforators / Stock Perf Blades
- page 25 - In-Line Rotary Perf Attachments / Custom Perf Blades
- page 26 - Slit & Pin Vent Attachments / Vent Punches
- page 27 - Vent Punching Attachments / Vent Punches
- page 28 - Slitter Blades & Safety Cutters / Slitting Attachment
- page 29 - Oscillating Slitter
- page 30 - Spreader Bars
- page 31 - Folding Boards / Turning Bar
- page 32 - Cross Rail Carriages
- page 33 - Custom Attachments / Custom Shape Punches

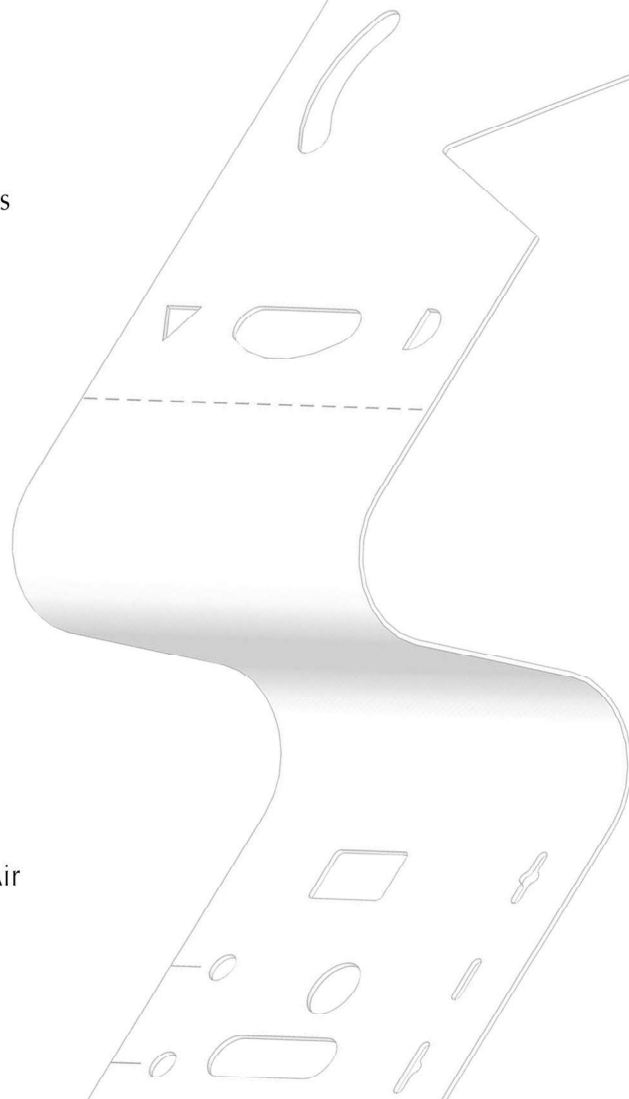

1 Piece vs. 2 Piece Design

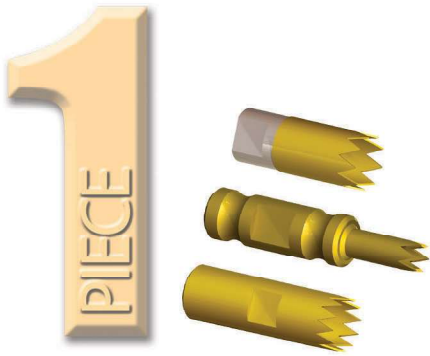

Traditional 1-Piece Design

The industry standard. Pearl offers many retrofit and custom punches for any application.

Look for the **1** and **2** symbols, as shown above, on the following pages of the catalog to help determine which design is best for your application!

Pearl originally fabricated the two piece design (punch & adapter) to allow customers the ability to create various overall lengths by simply changing the adapter. Punches are 1" long, but when combined with an adapter, lengths of 1", 1-1/4", 1-3/8", 1-1/2", 1-5/8", 1-3/4" and 2" can be achieved.

Benefits of the 2-Piece Design

- **Lower Cost Replacement Punches-** Worn or damaged punches require changing only the punch.
- **Increased Air Cylinder Life-** When using aluminum adapters, punch weight is reduced, increasing cylinder life.
- **Universal Adapter-** Small diameter round and vent punches all fit universal adapters.
- **Length Flexibility-** Wide array of adapter lengths allows for inexpensive fine-tuning of punch length with a single punch.
- **Easy Maintenance-** Utilizes tool-less installation, eliminating potential tool or plier damage to teeth.
- **Tool-less-** Included o-ring acts as a locking device to keep punch tight; hand tightening only.
- **Slug-Free-** All punches available with ejection rivets, eliminating the need to purchase blow through cylinders.
- **Metric Threads-** Adapters available in metric threads.

Punches for Every Application



Piranha
World's sharpest and longest lasting punch for all films.



Barracuda
World's best and longest lasting punch for films including linear low.



Shark
Strong teeth to cut through the toughest of films.



Tru-Kote
Our standard coated punch designed to outlast the competition.



Plastic
Our original low cost self-sharpening, light weight punch.

Retrofit Punches for Park Air

- Custom Punches
- Long-life Coating
- Exact Retrofits



Punch Diameter	Part Number	Overall Length	Thread Size
Round Hole Punches			
1/8"	SCR-18P-PA/2	2"	1/4-28
1/4"	SCR-14-PA/2	2"	1/4-28
	SCR-14-PA/112	1-1/2"	1/4-28
	SCR-14P-PA/2	2"	1/4-28
5/16"	SCR-516-PA/2	2"	1/4-28
	SCR-516-PA/112	1-1/2"	1/4-28
	SCR-516P-PA/2	2"	1/4-28
3/8"	SCR-38-PA/2	2"	1/4-28
	SCR-38-PA/112	1-1/2"	1/4-28
	SCR-38P-PA/2	2"	1/4-28
1/2"	SCR-12-PA/2	2"	1/4-28
	SCR-12-PA/112	1-1/2"	1/4-28
	SCR-12P-PA/2	2"	1/4-28
5/8"	SCR-58-PA/2	2"	1/4-28
	SCR-58-PA/112	1-1/2"	1/4-28
Butterfly Punches			
1/4"	SCB-14-PA/2	2"	1/4-28
3/8"	SCB-38-PA/2	2"	1/4-28

Punch Diameter	Part Number	Overall Length	Thread Size
Round Hole Punches			
3mm	SCR-3MM-PA/2	2"	1/4-28
	SCR-3MMP-PA/2	2"	1/4-28
4mm	SCR-4MM-PA/2	2"	1/4-28
	SCR-4MMP-PA/2	2"	1/4-28
5mm	SCR-5MM-PA/2	2"	1/4-28
	SCR-5MMP-PA/2	2"	1/4-28
6mm	SCR-6MM-PA/2	2"	1/4-28
	SCR-6MMP-PA/2	2"	1/4-28
12mm	SCR-12MM-PA/2	2"	1/4-28
Butterfly Punches			
3mm	SCB-3MM-PA/2	2"	1/4-28
4mm	SCB-4MM-PA/2	2"	1/4-28
5mm	SCB-5MM-PA/2	2"	1/4-28
6mm	SCB-6MM-PA/2	2"	1/4-28

Tear Notch Punches

- Long Lasting Punches
- Variety of Mounts & Lengths
- Catalog Sizes In-Stock
- Custom Built to Any Size



Punch Shape:

Punch Size	Part Number
1/8" x 1/4"	TN-18X14P/112
3/32" x 1/4"	TN-332X14P-PA/2
3/16" x 5/16"	TN-316X516P-PA/2

Retrofit Punches for Totani

- New Design that Keeps the Best of the Originals
- Whitworth Thread
- Long-life Pearl Coating
- Blow-thru Design



Punch Diameter	Part Number	Description
3mm	SCR-3MM-TW	Tru-Kote, 1/4-20 male whitworth thread and wrench flats
4mm	SCR-4MM-TW	Tru-Kote, 1/4-20 male whitworth thread and wrench flats
5mm	SCR-5MM-TW	Tru-Kote, 1/4-20 male whitworth thread and wrench flats
6mm	SCR-6MM-TW	Tru-Kote, 1/4-20 male whitworth thread and wrench flats
8mm	SCR-8MM-TW	Tru-Kote, 1/4-20 male whitworth threads and wrench flats
10mm	SCR-10MM-TW	Tru-Kote, 1/4-20 male whitworth thread and wrench flats
12mm	SCR-12MM-TW	Tru-Kote, 1/4-20 male whitworth thread and wrench flats
15mm	SCR-15MM-TW	Tru-Kote, 1/4-20 male whitworth thread and wrench flats
16mm	SCR-16MM-TWC	Tru-Kote, 1/4-20 male whitworth thread and wrench flats with M4x.7 internal threads

Piranha & Barracuda Punches

**World's Sharpest and Longest
Lasting Punches for all Films**

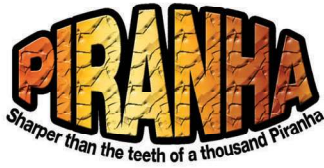

1
PIECE

- Custom Diameters, Lengths & Mounting Threads Available*
- Optional Airless Slug Ejection
- Outlasts Any Punch by 10-20 Times



Punch Diameter	Part Number	Overall Length
1/8"	SCR-18P/112	1-1/2"
3/16"	SCR-316P/112	1-1/2"
1/4"	SCR-14P/112	1-1/2"
5/16"	SCR-516P/112	1-1/2"
3/8"	SCR-38P/112	1-1/2"
3/8"	SCR-38P/112-HR	1-1/2"
7/16"	SCR-716P/112	1-1/2"
7/16"	SCR-716P/112-HR	1-1/2"
1/2"	SCR-12P/112	1-1/2"
1/2"	SCR-12P/112-HR	1-1/2"
9/16"	SCR-916P/112	1-1/2"
9/16"	SCR-916P/112-HR	1-1/2"
5/8"	SCR-58P/112	1-1/2"
5/8"	SCR-58P/112-HR	1-1/2"
3/4"	SCR-34P/112	1-1/2"
3/4"	SCR-34P/112-HR	1-1/2"
1"	SCR-1P/112	1-1/2"
1"	SCR-1P/112-HR	1-1/2"
1-1/8"	SCR-118P/112	1-1/2"
1-1/4"	SCR-114P/112	1-1/2"
1-1/2"	SCR-112P/112	1-1/2"
1-5/8"	SCR-158P/112	1-1/2"
1-11/16"	SCR-11116P/58	5/8"
1-3/4"	SCR-134P/1	1"
1-15/16"	SCR-11516P/58	5/8"
2"	SCR-2P/1	1"
2-1/4"	SCR-214P/134-C1	1-3/4"
2-1/2"	SCR-212P/134	1-3/4"
2-3/4"	SCR-234P/1	1"
3"	SCR-3P/134	1-3/4"

Punch Size	Part Number	Overall Length
1/2"	SCR-12B/112	1-1/2"
1/2"	SCR-12B/112-HR	1-1/2"
9/16"	SCR-916B/112	1-1/2"
9/16"	SCR-916B/112-HR	1-1/2"
5/8"	SCR-58B/112	1-1/2"
5/8"	SCR-58B/112-HR	1-1/2"
3/4"	SCR-34B/112	1-1/2"
3/4"	SCR-34B/112-HR	1-1/2"
1"	SCR-1B/112	1-1/2"
1"	SCR-1B/112-HR	1-1/2"
1-1/4"	SCR-114B/112	1-1/2"
1-1/2"	SCR-112B/1-C1	1"
1-3/4"	SCR-134B/1	1"
2"	SCR-2B/1	1"
2-1/4"	SCR-214B/134-C1	1-3/4"
2-1/2"	SCR-212B/112	1-1/2"
2-3/4"	SCR-234B/112-C1	1-1/2"
3"	SCR-3B/2516	2-5/16"
4"	SCR-4B/2516	2-5/16"
5"	SCR-5B/2516	2-5/16"

HR = heavy rivet



5.333 teeth per inch



16 teeth per inch



*standard mounting thread 1/4-28"

Tru-Kote Punches

- High Quality, Long-life Coating
- 2-piece Design Saves Money
- Change Without Tools
- Custom Diameters, Lengths & Mounting Threads Available
- In-stock/Ready to Ship!

TRU-KOTE

2
PIECE



Punch Diameter	Part Number	Part Number
	Tru-Kote	Shark
1/8"	SCR-18/1	
3/16"	SCR-316/1	
1/4"	SCR-14/1	
5/16"	SCR-516/1	
3/8"	SCR-38/1	SCR-38S/1
7/16"	SCR-716/1	SCR-716S/1
1/2"	SCR-12/1	SCR-12S/1
9/16"	SCR-916/1	SCR-916S/1
5/8"	SCR-58/1	SCR-58S/1
3/4"	SCR-34/1	
7/8"	SCR-78/1	
1"	SCR-1/1	

→ To be used with SCA-UNIV adapters for desired length

Metric:

Punch Diameter	Part Number
4mm	SCR-4MM/1
6mm	SCR-6MM/1
8mm	SCR-8MM/1
9mm	SCR-9MM/1
10mm	SCR-10MM/1

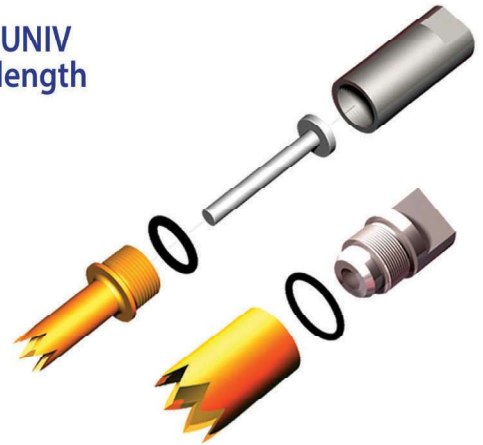

Shark Punches

- For Use on Heavy Film
- Strong Teeth
- Long-life Coating
- Custom Diameters, Lengths & Mounting Threads Available

Takes a big bite out of thick films!

SHARK

2
PIECE



Tru-Kote Punch Adapters

Punch Diameter	Part Number	Material	OAL w/ Punch	Thread Size
1/8" - 7/16" punches & 4-10mm	SCA-UNIV/114	Aluminum	1-1/4"	1/4-28
	SCA-UNIV/114-M8	Aluminum	1-1/4"	M8
	SCA-UNIV/138	Aluminum	1-3/8"	1/4-28
	SCA-UNIV/112	Aluminum	1-1/2"	1/4-28
	SCA-UNIV/112-M6	Aluminum	1-1/2"	M6
	SCA-UNIV/112S-M8	Steel	1-1/2"	M8
	SCA-UNIV/1916S	Steel	1-9/16"	1/4-28
	SCA-UNIV/158S	Steel	1-5/8"	1/4-28
	SCA-UNIV/134	Aluminum	1-3/4"	1/4-28
	SCA-UNIV/134S-M6	Steel	1-3/4"	M6
1/2" punches	SCA-12/114S	Steel	1-1/4"	1/4-28
	SCA-12/112	Aluminum	1-1/2"	1/4-28
	SCA-12/112-M6	Aluminum	1-1/2"	M6
	SCA-12/112-M8	Aluminum	1-1/2"	M8
	SCA-12/134S-M8	Steel	1-3/4"	M8
	SCA-12/2	Aluminum	2"	1/4-28
9/16" punches	SCA-916/112	Aluminum	1-1/2"	1/4-28
	SCA-916/112S-M6	Steel	1-1/2"	M6
5/8" punches	SCA-58/114S	Steel	1-1/4"	1/4-28
	SCA-58/112	Aluminum	1-1/2"	1/4-28
	SCA-58/112S	Steel	1-1/2"	M6
	SCA-58/112S-M6	Aluminum	1-1/2"	1/4-28
3/4" punches	SCA-34/112	Aluminum	1-1/2"	1/4-28
	SCA-34/112-M6	Steel	1-1/2"	M6
7/8" punches	SCA-78/112S	Steel	1-1/2"	1/4-28
1" punches	SCA-1/112S	Steel	1-1/2"	1/4-28
	SCA-1/112	Aluminum	1-1/2"	1/4-28

- Available in Aluminum or Steel
- Custom Lengths or Metric Threads
- Reusable



Call for comparable sizes and pricing!

Slug Ejectors

- Reusable
- Reduce Air Consumption
- Save Money



Part Number	Used with:
SCR-RVT	SCR-14/1
	SCR-516/1
	SCR-38/1
	PCR-38/1
metric sizes: SCR-6MM/1, SCR-8MM/1	



Part Number	Used with:
SCR-RVT-2	SCR-18/1
	SCR-316/1
metric sizes: SCR-4MM/1	



Part Number	Used with:
SCR-RVT-3	SCR-38/1
	SCR-716/1
metric sizes: SCR-9MM/1, SCR-10MM/1	

Handle Hole Punches

- High Quality Holes
- Any Size, Any Shape
- Exact Retrofits for Park-Air & Ro-an
- Custom Diameters, Lengths & Mount Threads Available

Punch Dimensions	Part Number			
	Banana	Oval	Modified	"C" Cut
3/4" x 3"		*HHO-34X3B *HHO-34X3P		*HHO-34X3B-C *HHO-34X3P-C
3/4" x 2-1/2"	HHB-34X212P	HHO-34X212B HHO-34X212P		
3/4" x 3-1/2"	*HHB-34X312B *HHB-34X312P	*HHO-34X312P *HHO-34X312B		*HHB-34X312B-C *HHB-34X312P-C
1" x 3"		HHO-1X3B HHO-1X3P		
1" x 3-1/4"	HHB-1X314B			HHB-1X314B-C
1" x 3-1/2"		*HHO-1X312 *HHO-1X312P *HHO-1X312B	HHMO-1X312P HHMO-1X312B	*HHO-1X312C *HHO-1X312P-C *HHO-1X312B-C
1" x 3-5/8"			*HHMO-1X358	*HHMO-1X358-C

* plastic, * Ro-an and Park-Air Retrofits In-Stock, " = inches

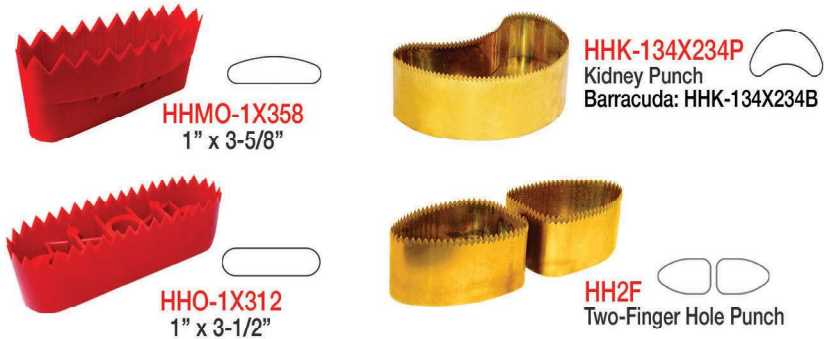
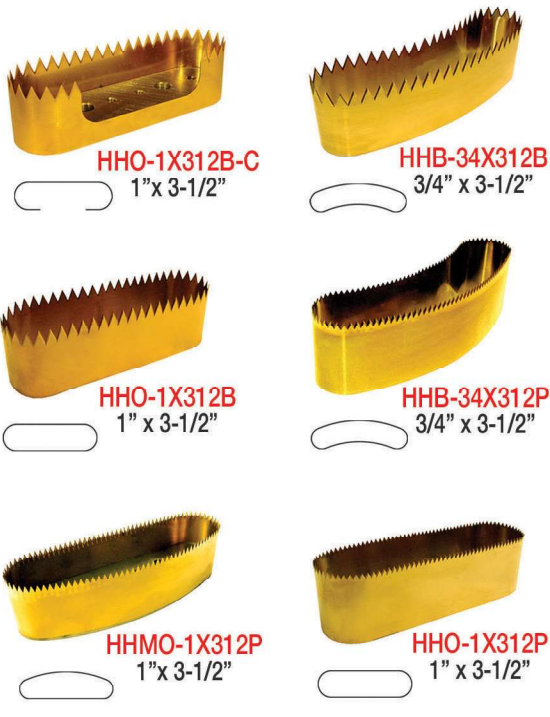

Hanger Hole Punches

- Piranha Super Punches
- Clean, Smooth Holes
- English or Metric
- Custom Sizes & Shapes Available

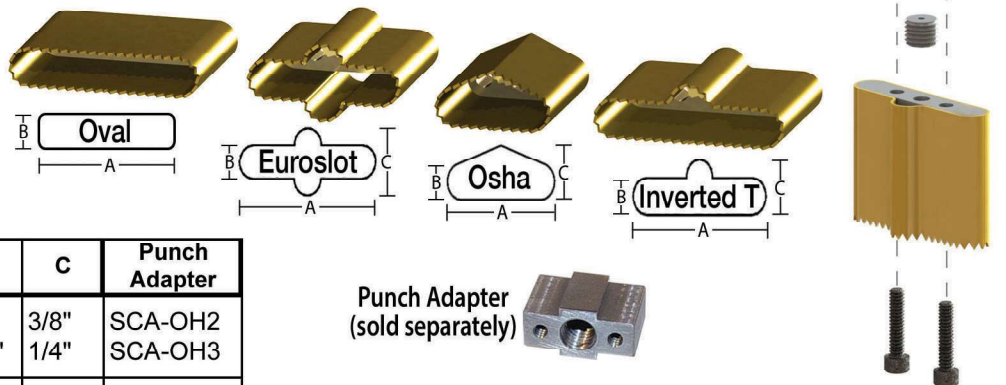

Shape	Part Number	A	B	C	Punch Adapter
Osha	SCOS-58P	5/8"	1/4"	3/8"	SCA-OH2
Osha	SCOS-58X14P	5/8"	5/32"	1/4"	SCA-OH3
Osha	SCOS-12P	1/2"	1/4"	3/8"	SCA-OH2
Osha	SCOS-34P	3/4"	1/4"	3/8"	SCA-OH
Osha	SCOS-1P	1"	1/4"	3/8"	SCA-OH
Osha	SCOS-1P-PA	1"	1/4"	3/8"	-
Oval	SCO-1X14P	1"	1/4"	-	SCA-OH
Osha	SCOS-114P	1-1/4"	1/4"	3/8"	SCA-OH
Osha	SCOS-114P-PA	1-1/4"	1/4"	3/8"	-
Osha	SCOS-1716P	1-7/16"	1/4"	3/8"	SCA-OH

Shape	Part Number	A	B	C	Punch Adapter
Inverted T	SCT-1P	1"	1/4"	3/8"	SCA-OH
Inverted T	SCT-1P-PA	1"	1/4"	3/8"	-
Inverted T	SCT-1X316X14P	1"	3/16"	1/4"	SCA-OH
Inverted T	SCT-114P	1-1/4"	1/4"	3/8"	SCA-OH
Inverted T	SCT-114P-PA	1-1/4"	1/4"	3/8"	-
Inverted T	SCT-114X316X14P	1-1/4"	3/16"	1/4"	-
Euroslot	SCES-114P	1-1/4"	1/4"	1/2"	SCA-OH

Plastic Punches that Work!

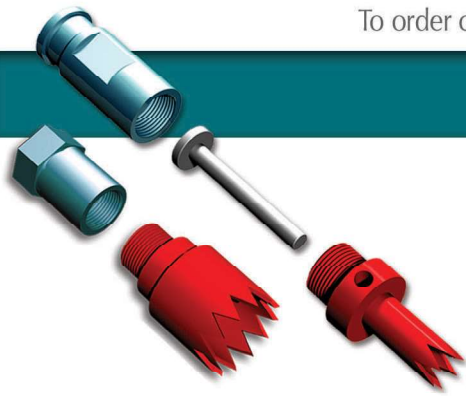

Plastic punches have been used for over two decades with great success. They do not damage when dropped. Unique, self-sharpening design yields excellent punch life. All punches screw into one of the adapters below, to determine overall length.

- Ultra-light
- Self-sharpening
- Inexpensive
- Employee Safe

Punch Diameter	Part Number w/o Slug Ejection	Part Number w/ Slug Ejection
1/8"	PCR-18	-
1/4"	PCR-14	PCR-14R
3/8"	PCR-38	PCR-38A
7/16"	PCR-716	PCR-716A
1/2"	PCR-12	PCR-12A
9/16"	PCR-916	PCR-916A
5/8"	PCR-58	PCR-58A
3/4"	PCR-34	PCR-34A
1"	PCR-1	PCR-1A
1 1/2"	PCR-112	PCR-112A
2"	PCR-2	PCR-2A
2 1/2"	PCR-212	PCR-212A

→ To be used with PCA Adapters

2
PIECE

Redhead
the original self-sharpening punch



SUFFIX LETTER KEY FOR SLUG EJECTION:

No suffix = plain punch, A = air sponge, R = rivet, " = inches

Plastic Punch Adapters

Punch Diameter	Part Number	Material	OAL w/ Punch	Thread Size
1/8" - 1"	PCA-114	Aluminum	1-1/4"	1/4-28
	PCA-138P	Plastic	1-3/8"	1/4-28
	PCA-112	Plastic	1-1/2"	1/4-28
	PCA-112A	Aluminum	1-1/2"	1/4-28
	PCA-112B	Brass	1-1/2"	1/4-28
	PCA-112C	Brass	1-1/2"	5/16-24
	PCA-112D	Brass	1-1/2"	3/8-24
1/8" - 7/16"	PCA-2	Aluminum	2"	1/4-28
	PCA-2P	Plastic	2"	1/4-28
	PCA-2S	Steel	2"	1/4-28
1/8" - 7/16"	PCA-COM1	Plastic	Punch & slitter combo adapter, non-adjustable gap	1/4-28
	PCA-COM2	Plastic	Punch & slitter combo adapter, adjustable gap	1/4-28
1-1/2" - 2-1/2"	PCA-LG	Aluminum		1/4-28
	PCA-LGB	Brass		1/4-28

- Lightweight
- Universal Fit
- Reusable



PCA-114



PCA-112A



PCA-2



PCA-LG



PCA-COM1



PCA-COM2

Repairable Air Cylinders

- High Speed Design
- Quiet Operation
- Blow-thru Shaft
- Built to Last

AIR CYLINDER (Part Number)	BORE	STROKE	A	B	C	D	E	F	G	H	SPRING RETURN	DUAL ACTING	NON-ROTATE	QUICK CONNECT	BLOW THRU	UNIT NAME
AC34C-B	0.75	1.00	1/2 - 20	1/4 - 28	1.125	0.500	0.375	2.125	1/8 NPT	0.886	●				●	
ACR34C-34HP	0.75	0.75	1/2 - 20	1/4 - 28	1.580	0.500	0.500	2.750	1/8 NPT	1.000	●				●	
ACR34CNR-34HP	0.75	0.75	1/2 - 20	1/4 - 28	1.580	0.500	0.500	2.750	1/8 NPT	1.000	●		●		●	Multi-Punch Units
ACR34CCM-34HP	0.75	0.75	1/2 - 20	N/A	1.580	0.500	0.500	2.750	1/8 NPT	1.000	●					
AC-1C	1.00	0.75	5/8 - 18	1/4 - 28	1.500	0.750	0.625	1.900	1/8 NPT	1.250	●				●	

**Also available* -- call for repair kits/replacement kits*

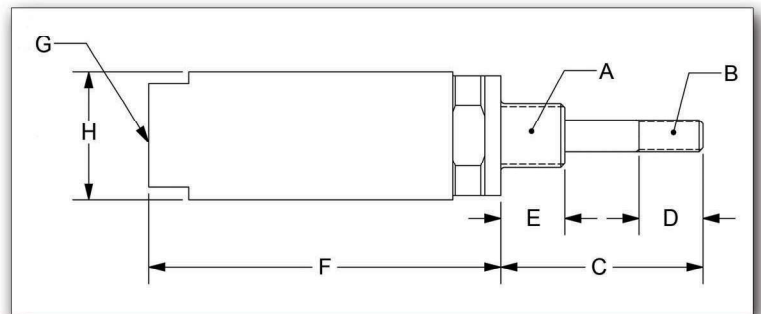

Non-Repairable Air Cylinders

- Long-life
- High Quality
- Quiet Operation
- Custom Cylinders Available

AIR CYLINDER (Part Number)	BORE	STROKE	A	B	C	D	E	F	G	H	SPRING RETURN	DUAL ACTING	NON-ROTATE	QUICK CONNECT	BLOW THRU
AC-3478-DA	0.75	0.88	5/8 - 18	1/4 - 28	1.750	0.500	0.500	3.375	1/8 NPT	0.859		●			●
AC34C-34HP	0.75	0.75	1/2 - 20	1/4 - 28	1.750	0.875	0.438	2.715	1/8 NPT	0.813	●				●
AC34C-1HP	0.75	1.00	1/2 - 20	1/4 - 28	1.750	0.875	0.438	3.000	1/8 NPT	0.813	●				●
AC34C-1HPQ	0.75	1.00	1/2 - 20	1/4 - 28	1.750	0.875	0.438	3.000	1/4 "	0.813	●			●	●
AC34C-34HPQ	0.75	0.75	1/2 - 20	1/4 - 28	1.750	0.875	0.438	2.715	1/4 "	0.813	●			●	●
AC34CNR-1HP	0.75	1.00	1/2 - 20	1/4 - 28	1.750	0.875	0.438	3.000	1/8 NPT	0.813	●		●		●
AC34CNR-34HP	0.75	0.75	1/2 - 20	1/4 - 28	1.750	0.875	0.438	2.715	1/8 NPT	0.813	●		●		●
AC34CNR-34DA	0.75	0.75	5/8 - 18	1/4 - 28	1.750	0.500	0.500	3.234	1/8 NPT	0.813		●	●		●
AC34CNR-1HP	0.75	1.00	1/2 - 20	1/4 - 28	1.750	0.875	0.438	3.000	1/8 NPT	0.813	●		●		
AC34CNR-34HP	0.75	0.75	1/2 - 20	1/4 - 28	1.750	0.875	0.438	2.715	1/8 NPT	0.813	●		●		
AC34C-34HP6MQ	0.75	0.75	1/2 - 20	1/4 - 28	1.750	0.875	0.438	2.715	6 MM	0.813	●			●	●
AC-2CDA	2.00	1.00	1 1/4 - 12	1/2 - 20	2.125	0.875	0.812	4.750	1/4 NPT	2.078		●			
AC-2CDA-BT	2.00	1.00	1 1/4 - 12	1/2 - 20	2.125	0.875	0.812	5.500	1/4 NPT	2.078		●			●



Wicket Hub Assemblies

WEAR-RESISTANT Pearl-Grip Arms

Tool-less arm removal.

End cap is leak-proof as well as tool-less.

Textured grip integrated into surface of the arms.

Will not peel or warp with heat or solvent baths.

Will not chip upon impact.

- Tool-less Arm & End Cap Removal
- Split Bearings for Quick Changes
- Tool-less Hub Locks
- 6 & 8 Arm Hub Sets in Stock
- Custom Sets Made to Order



PVH-S6-WR

Vacuum Hub Set, aluminum, 8" diameter, includes (2) vacuum halves; (2) rotary halves; (2) drive rings; (12) wear resistant "Pearl-Grip" arms with tool-less arm removal system, removable end caps, replaceable bearing surfaces.



PVH-PAWR

Wicket Arm, 14-9/16" OAL* (exposed from hub) (16-1/4" OAL)
1" x 1" square tubing with wear-resistant coating.



PVH-S8-WR

Vacuum Hub Set, aluminum, 8" diameter, includes (2) vacuum halves; (2) rotary halves; (2) drive rings; (16) wear resistant "Pearl-Grip" arms with tool-less arm removal system, removable end caps, replaceable bearing surfaces.

patented

Retrofit Arms

Retrofit Arms Available
Upon Request

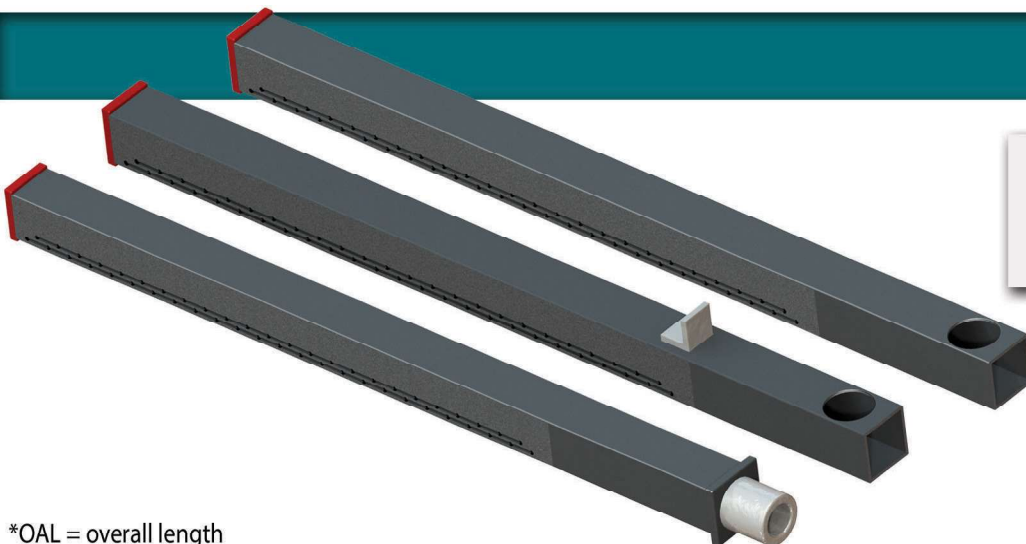

*OAL = overall length

30-day product guarantee

Side Rail Sealing Attachment

- Temperature Controller
- 4-3/4" Square Sealing Area
- Various Sealing Profiles Available
- Orient Seal Shapes by Rotating 90°
- Custom Shapes



Temperature Controller

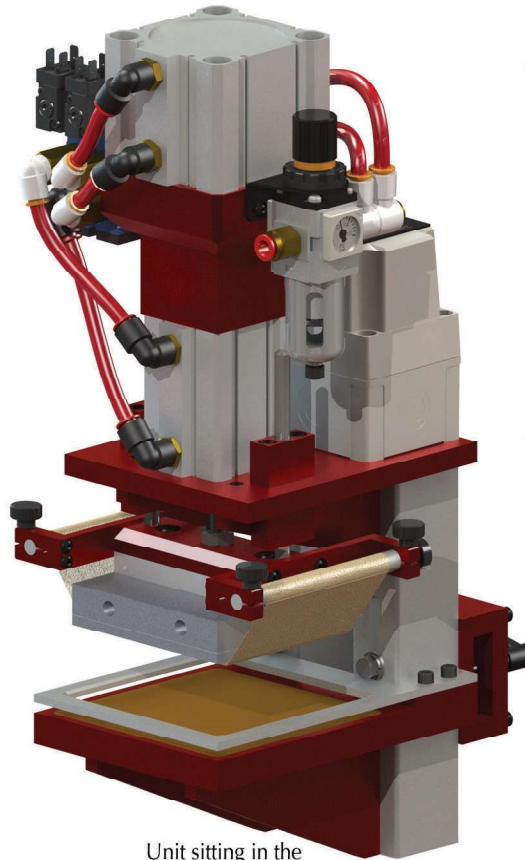

Unit sitting in the e-stop position



Pearl's hole punch "security" sealer is a modifiable unit with interchangeable patterns, adjustable temperature control, and customizable sizes. The sealer is equipped with Teflon film rollers and includes a retractable emergency stop position.

Spin Punch Attachment

- Cuts Clean, High Quality Round Holes
- Minimum Diameter: 1-1/4"
- Uses Same Air Pressure as a Flex Unit
- Side or Cross Rail Available

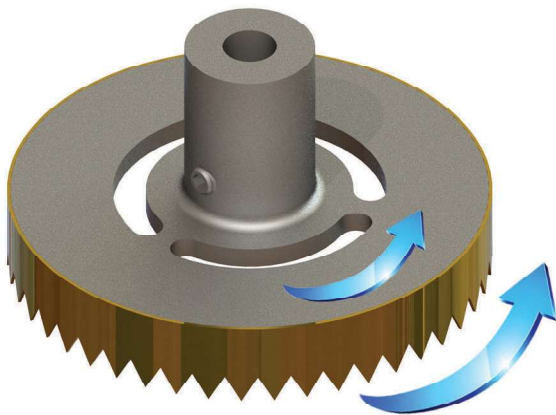

The spin-punch attachment brings significant cost savings by not requiring zero-clearance tooling to make perfectly clean, round holes.

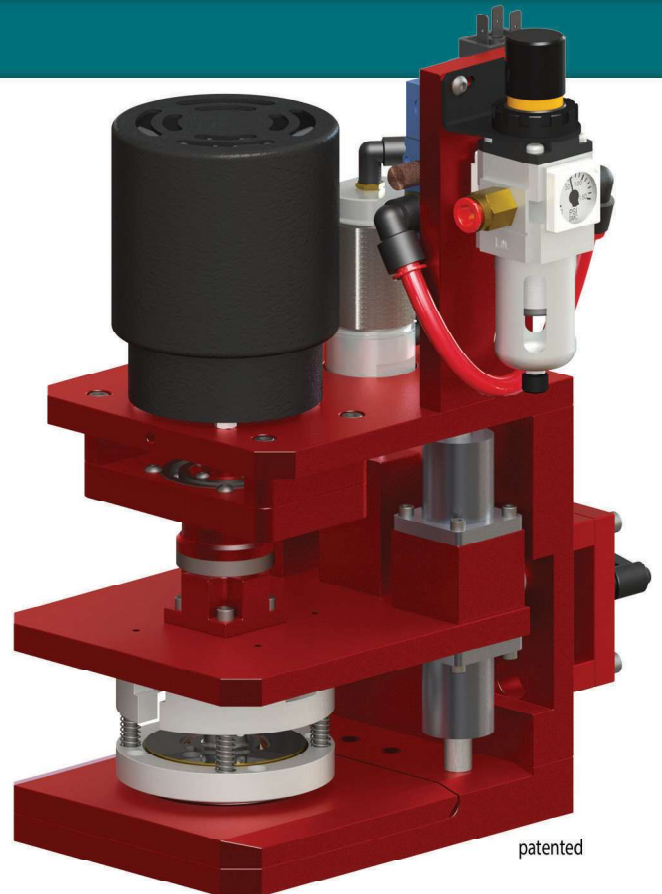

patented

**New Design
New Price**

Zero Clearance Punching



One of the finest
ZERO-CLEARANCE
punching systems...

- Hole Punch Perfection
- Punches Last Up to 10 Times Longer
- Built-in Alignment Guide to Prevent Crashes
- Compact Design
- Custom Shapes

Custom shapes and sizes to meet product specifications

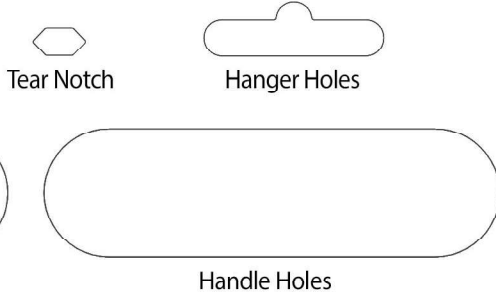

A line of *zero clearance* punching units that reflect Pearl's commitment to product quality, speed and unparalleled longevity. Nice, clean, crisp holes that won't propagate a tear. Ideal for packaging where hole perfection is required, such as medical packaging or easy-to-tear films.

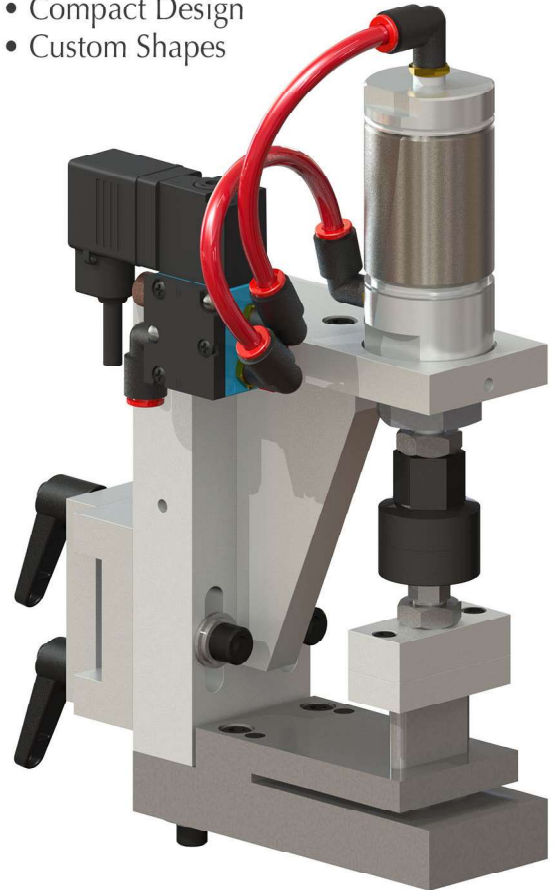

Crimper Attachment

- Bag Opening Made Easy
- Replaceable Upper and Lower Jaws
- Custom Sizes

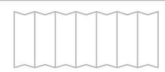
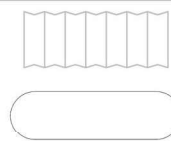
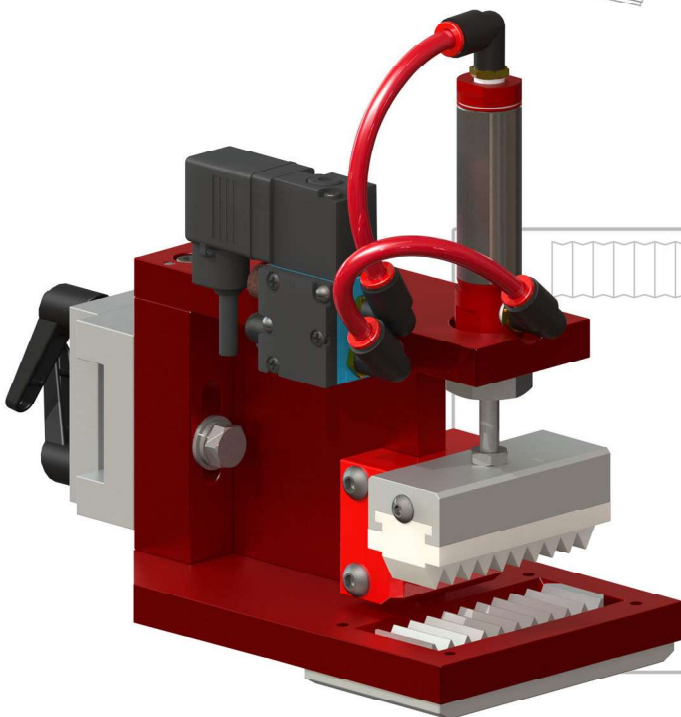

The crimper attachment is a simple installation that makes bags easier to open.

The Flex Concept

The Flex Unit for Multiple Punching Tasks!

Our innovative flexible design unit offers unique advantages over traditional punching, providing the ability to quickly change punch shapes and sizes. This allows film and pouch converters use of a single punching unit on several jobs. It's as simple as bolting on a die insert and punch which universally fit the "Flex Unit." Available in any shape or size to meet your exact specifications.

*Standard Voltages: 110 VAC, 220 VAC, 24 VAC, and 24 VDC

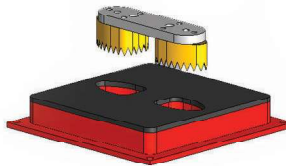

Punch & Die Insert
sold separately



Flex 1

Designed for Small Sized Punches

- Pin Vents, Rounds, Osha & Custom Shaped Punches
- Flexible for Punch Sizes Up to a Maximum of 1.375"
- Can Orient Punches MD or TD by Rotating Inserts 90°
- Available in Both Side Rail & Cross Rail Versions
- On Cross Rail as Close as 2.5" Center-to-Center
- Throat Depth for Side Rail Mount is 2"
- Call for Custom Sizes and Designs



FLEX 1

Flex 1 Side Rail



patented

Punch & Die Insert
sold separately

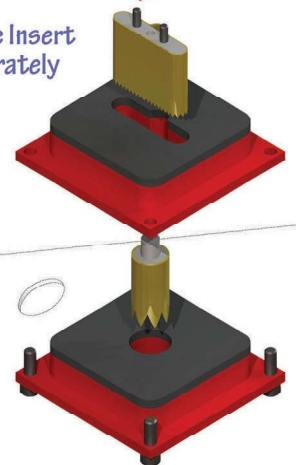

The following punches represent additional sizes available for Flex 1 Units:

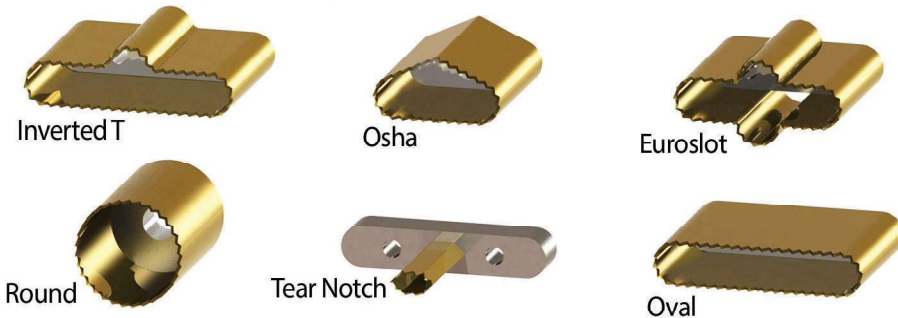

Inverted T

Osha

Euroslot

Round

Tear Notch

Oval



Flex 1 Cross Rail

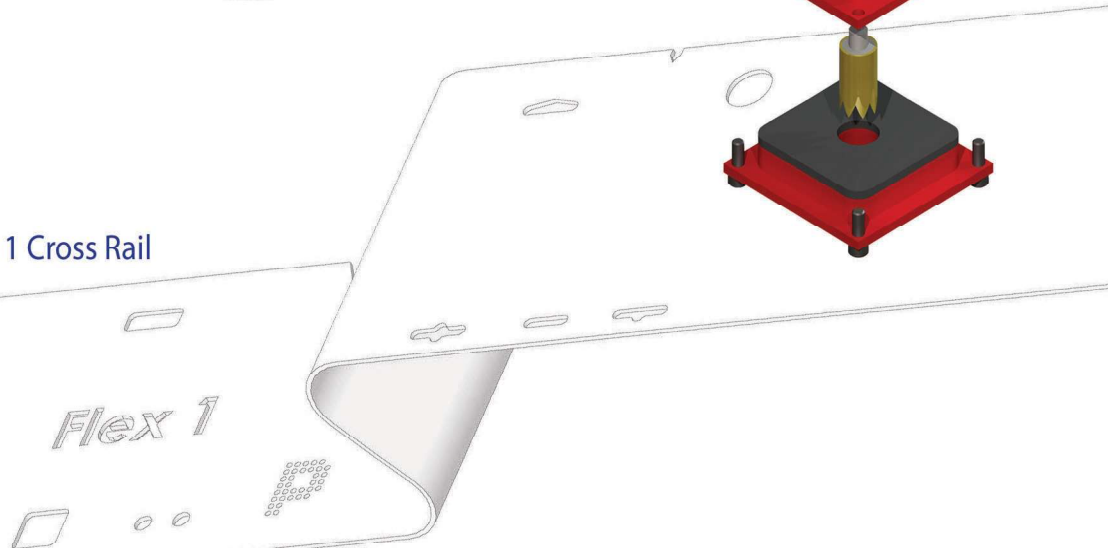

Flex 2

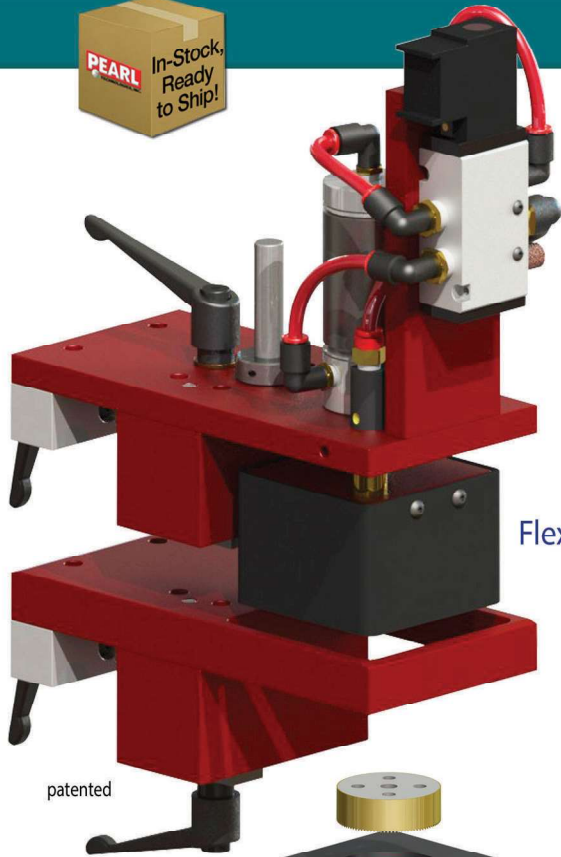

Flex 2 Cross Rail

Designed for Medium Sized Punches

- Rounds, Squares & Custom Shaped Punches
- Flexible for Punch Sizes Up to a Maximum of 2.8125"
- Can Orient Punches MD or TD by Rotating Inserts 90°
- Available in Both Side Rail & Cross Rail Versions
- On Cross Rail as Close as 4.0" Center-to-Center
- Throat Depth for Side Rail Mount is 3.0"
- Call for Custom Sizes and Designs



patented

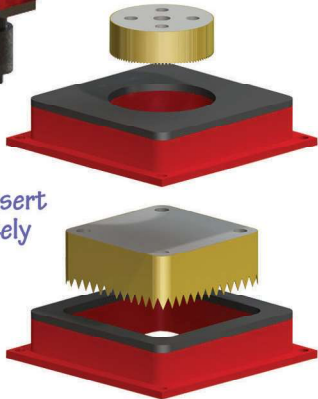

Punch & Die Insert
sold separately

The following punches represent
additional sizes available for Flex 2 Units:



Round

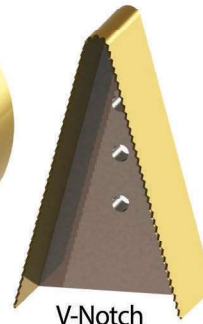

V-Notch

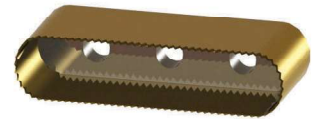

Oval



Osha



Inverted T



Flex 2 Side Rail

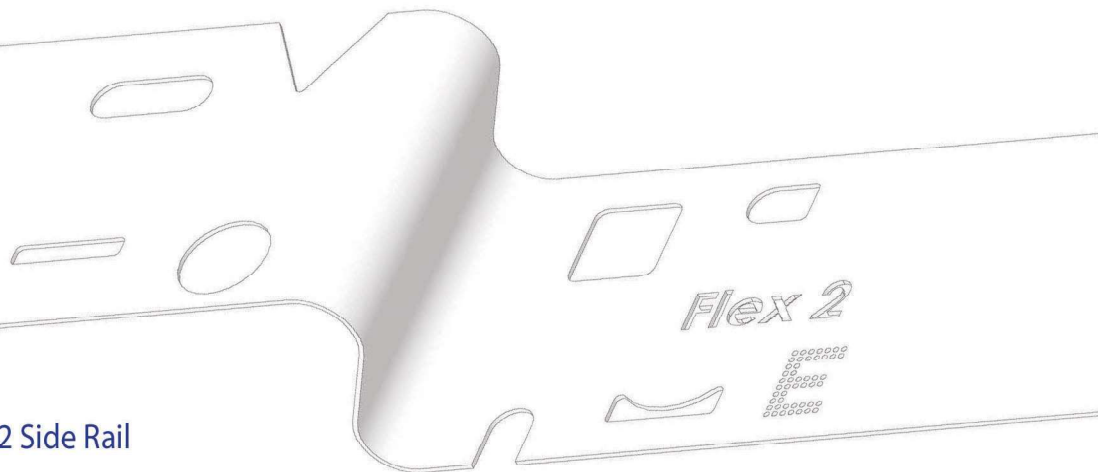

Flex 3



Designed for Handle Hole Punches

- Primarily for Handle Hole Punches of All Shapes & Sizes
- Single Web Clamp for all our Standard HHO Punches
- Can Orient Punches MD* or TD* by Rotating Inserts 90°
- Available in Both Side Rail and Cross Rail Versions
- On Cross Rail as Close as 5.5" Center-to-Center
- Flexible for Punch Sizes Up to Maximum of 3.5"
- Throat Depth for Side Rail Mount is 3.875"
- Call for Custom Sizes and Designs



Flex 3 Side Rail

patented

The following punches represent additional sizes available for Flex 3 Units:

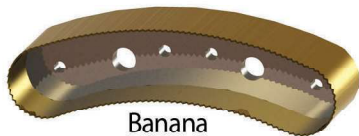

Banana

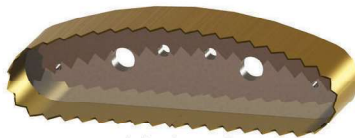

Modified Oval

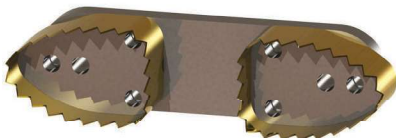

Two-Finger Hole Punch



Kidney Punch

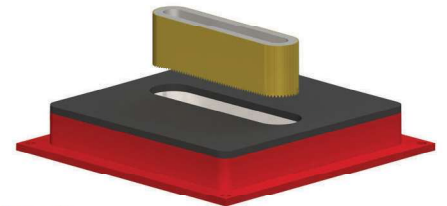

Punch & Die Insert sold separately

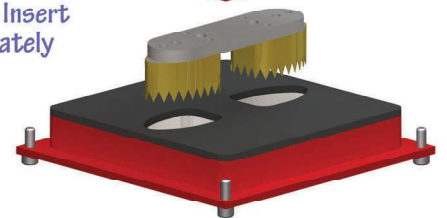

Flex 3 Cross Rail

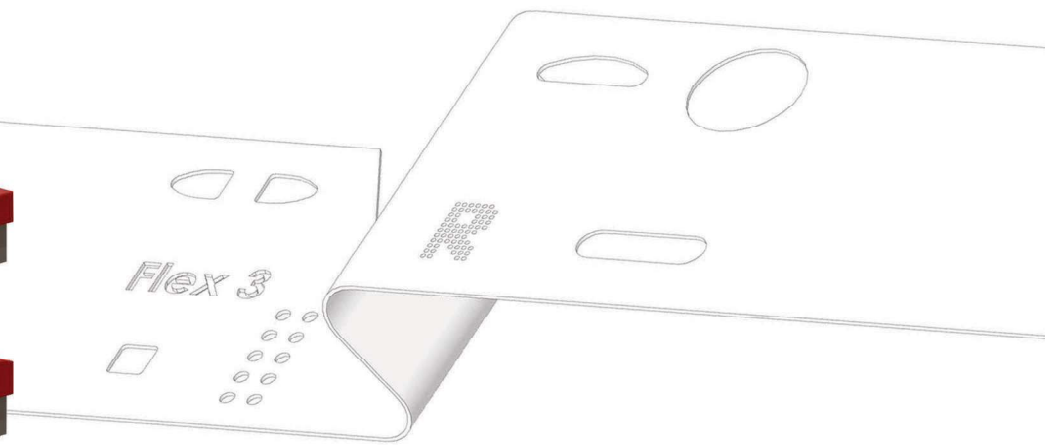

Flex 4



Flex 4 Cross Rail

Designed for Larger Sized Punches

- Takes V-Notch, Round & Custom Shaped Punches
- Flexible for Punch Sizes Up to Maximum of 5.0"
- Handles Big Punches with Ease
- Can Orient Punches MD or TD by Rotating Inserts 90°
- On Cross Rail as Close as 7.0" Center-to-Center
- Throat Depth for Side Rail Mount is 4.25"
- Call for Custom Sizes and Designs



The following punches represent additional sizes available for Flex 4 Units:

patented

Punch & Die Insert sold separately

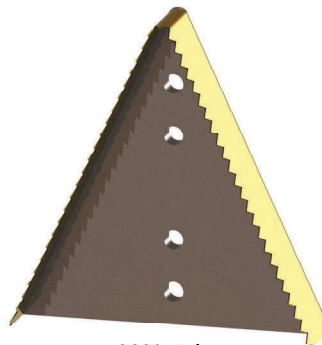

V-Notch

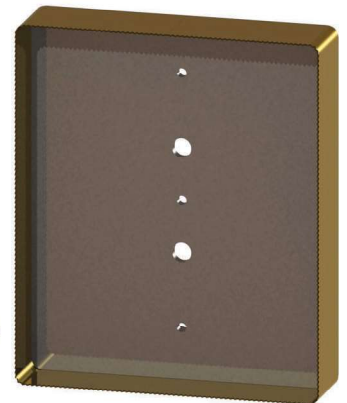

Rectangle

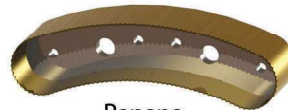

Banana

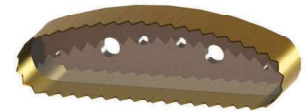

Modified Oval



Flex 4 Side Rail

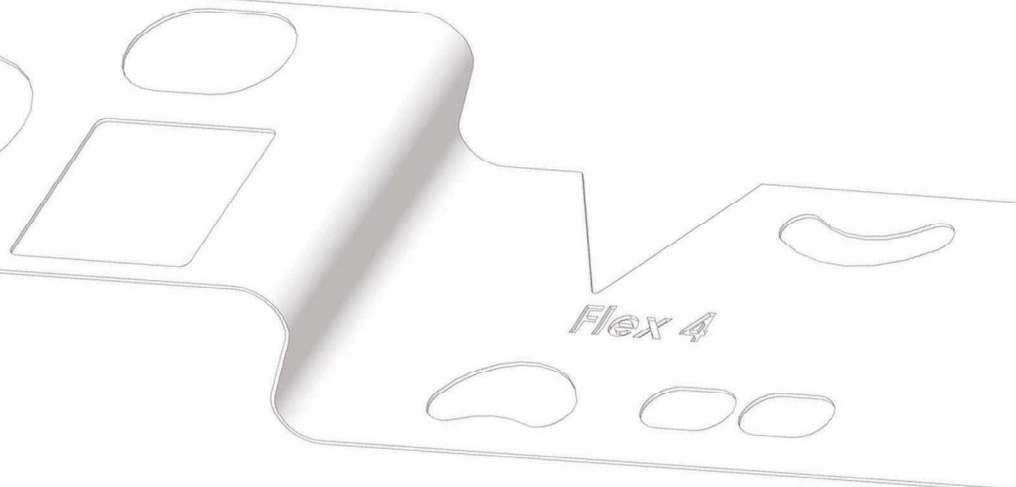

High Definition Punching

- High Quality Holes in Tough Films
- Recommended For Stretchy Films
- Available for Piranha and Barracuda Punches
- Varying Sizes of High Definition Holes
- Great for Large and Custom Shapes

Pearl's Hi-Definition punching system achieves our finest hole quality in difficult to punch and stretchy films. The Hi-Definition unit offers a tight tolerance system designed and controlled through our manufacturing process. Retrofit options are available for all of Pearl's Flex units. Take your dollar and quality further with Pearl's Hi-Definition unit!

A sample of some of the shapes available for our Hi-Def Flex Units:

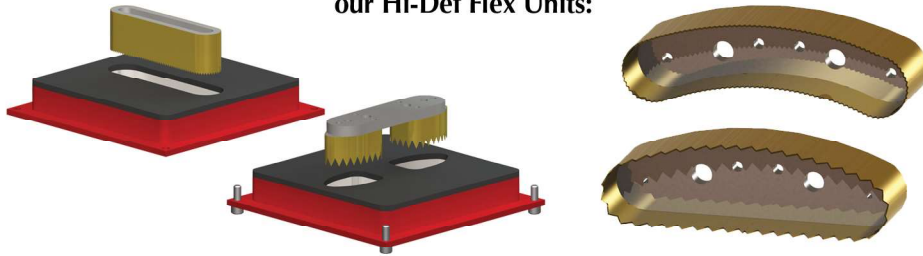

Patch Handle Attachment

- Reinforce Holes in Bags
- Cycles Up to 90 Bags Per Minute
- Independent Heater and Touch Screen Controls
- Various Patch Sizes Available



Unit Controls with Emergency Stop

Our servo-driven Patch Handle Attachment is designed to easily reinforce plastic bags. It can be mounted in the intermittent synchronize section of any bag machine and has independent controls to insert two layers of double wound, pre-slit film to the inside of the bag. These additional layers of plastic reinforce the handle hole area of the bag to allow for heavier loads without the fear of ripping or tearing. Once inserted into the bag, a knife cuts it off and seals the film patch to the bag.

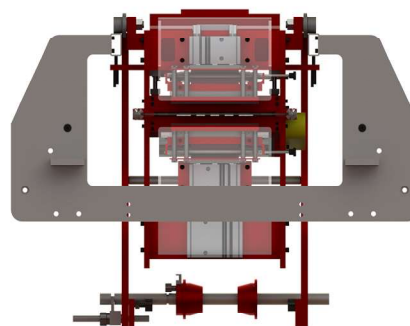

**New Design
New Price**

Drawstring Swipe-Cut Attachment



patent pending



Drawstring Swipe-Cut

This dual punch arm innovation is perfectly balanced to give you high quality holes at incredible speeds.

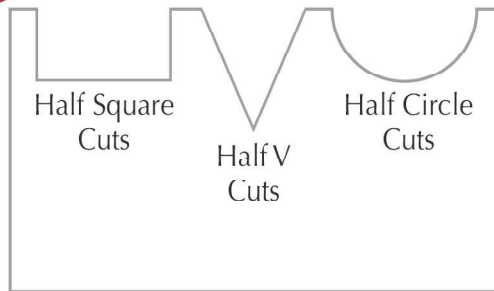

- 10 Times Longer Punch Life
- Superior Hole Quality
- High Speed
- Cycles up to 300 Feet Per Minute
- Punching-On-The-Fly
- Standard Diameters are 1-1/2" and 2" Round Punch
- Custom Shapes and Diameters Available Upon Request



Pearl's Hole Quality



Competitor's Hole Quality

Pivot Punch Attachment

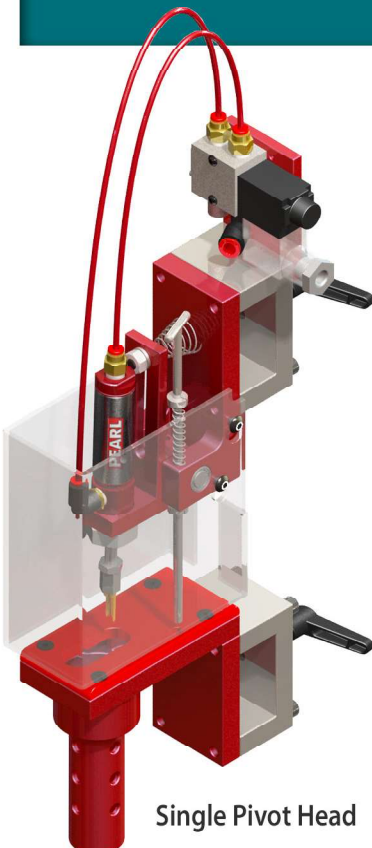

Single Pivot Head

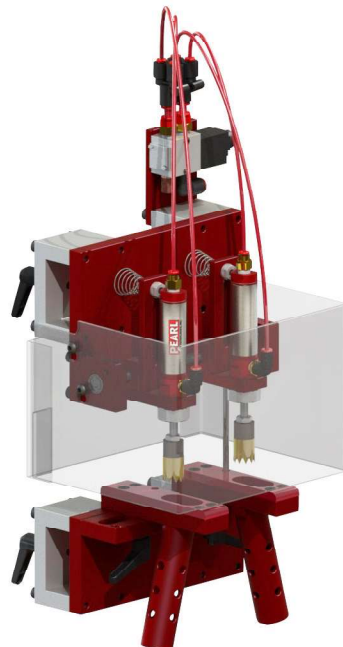

Double Pivot Head



Spring-loaded
Auto Alignment

- High-speed
- Great for Thick or Thin Webs
- Significant Noise Reduction
- Longer Punch Life
- Low Maintenance
- Cycles up to 300 Feet Per Minute

*A proven way
to punch
"On-the-Fly"*



patented

30-day product guarantee

Side Web C-Frame



- Adjusts to Web Height
- Available in 6", 8" & 12" Throat Depths
- Cycles up to 300 Feet Per Minute
- Custom Designs

Large Diameter C-Frame
Max hole size: 1-1/2"



The Standard Unit uses industry standard ball and dies as well as our own two-piece design. Our C-frame allows you to adjust die height, change the plunger and remove the air cylinder without any additional tools.

The Larger Diameter C-Frame uses our custom two-piece low profile punch and die design.

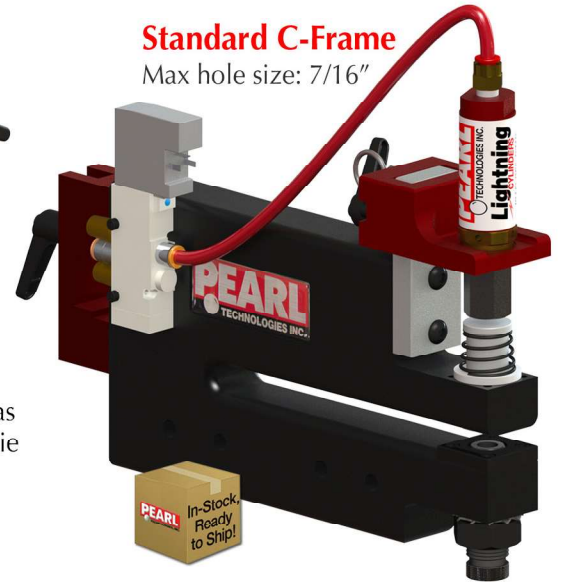

Standard C-Frame
Max hole size: 7/16"

Cross Web Ball & Die

New!



- Adjustable Mount
- Clean Holes
- Cycles up to 300 Feet Per Minute
- Custom Designs Upon Request

Our Cross Web Ball and Die design allows for hole punching in the middle of continuous motion webs. It contains a built-in alignment system to ensure the balls are centered over the dies. The Cross Web Ball and Die runs at speeds up to 600 cycles per minute and can be placed anywhere across the web!

See page 32 for carriage options!

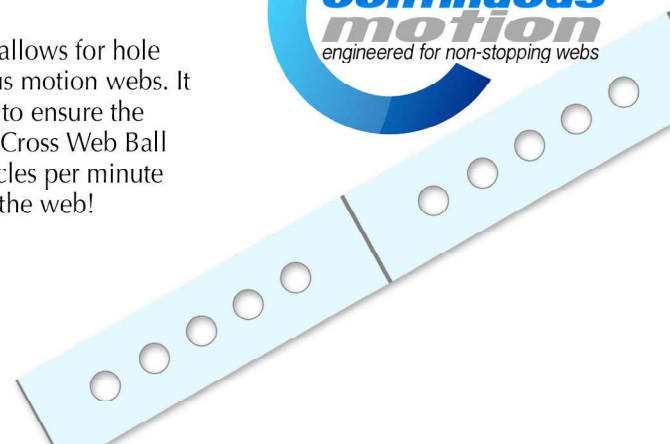

Hardened 2-Piece Plungers

New!

- Lightweight Plastic Plunger Reduces Sound
- One Plunger Fits All Punch Head Sizes
- Long Life Punch Heads
- Clean Cuts
- Higher Speeds

Pearl's new two-piece assembly utilizes a low profile punch head for stiffer laminate or thicker films. Both the die and punch can be reground for extended life.



Ball & Die Retrofit Parts for Park Air

- Plastic or Steel Ball Punches
- Exact Retrofits



Part Number	Description
PCMOB-01	Bushing
PCMOB-02	Reducing Bushing for 1/4" & 1/8"
PCMLN-34X1	3/4"x1" Lock Nut
PCM-ESA	Elevating Screw Assembly
PCM-01SPR	1/4"x1/8" Return Spring
PCM-02SPR	5/16", 3/8", 7/16" Return Spring
ACR34CCM-34HP	Repairable Air Cylinder, Complete
ACR-RKCM	Air Cylinder Repair Kit

Hole Size	Part Number	Description
	Steel / Plastic	
1/8"	PCMP-18 / PCMPP-18	Ball Punch
1/4"	PCMP-14 / PCMPP-14	Ball Punch
5/16"	PCMP-516 / PCMPP-516	Ball Punch
3/8"	PCMP-38 / PCMPP-38	Ball Punch
7/16"	PCMP-716 / PCMPP-716	Ball Punch
1/8"	PCMD-18	Die
1/4"	PCMD-14	Die
5/16"	PCMD-516	Die
3/8"	PCMD-38	Die
7/16"	PCMD-716	Die
1/8"	PCMDB-18	Butterfly Die
1/4"	PCMDB-14	Butterfly Die
5/16"	PCMDB-516	Butterfly Die
3/8"	PCMDB-38	Butterfly Die
7/16"	PCMDB-716	Butterfly Die
1/8"	PCMDX-18	Cross Cut Die
1/4"	PCMDX-14	Cross Cut Die
3/8"	PCMDX-38	Cross Cut Die
7/16"	PCMDX-716	Cross Cut Die

Cross Rail Perforators

New Design
New Price

- Uses Piranha and Barracuda Blades
- High Speed
- Built-In Clamp
- Standard Sizes in 12", 24", 36", & 48"
- Custom Lengths Available

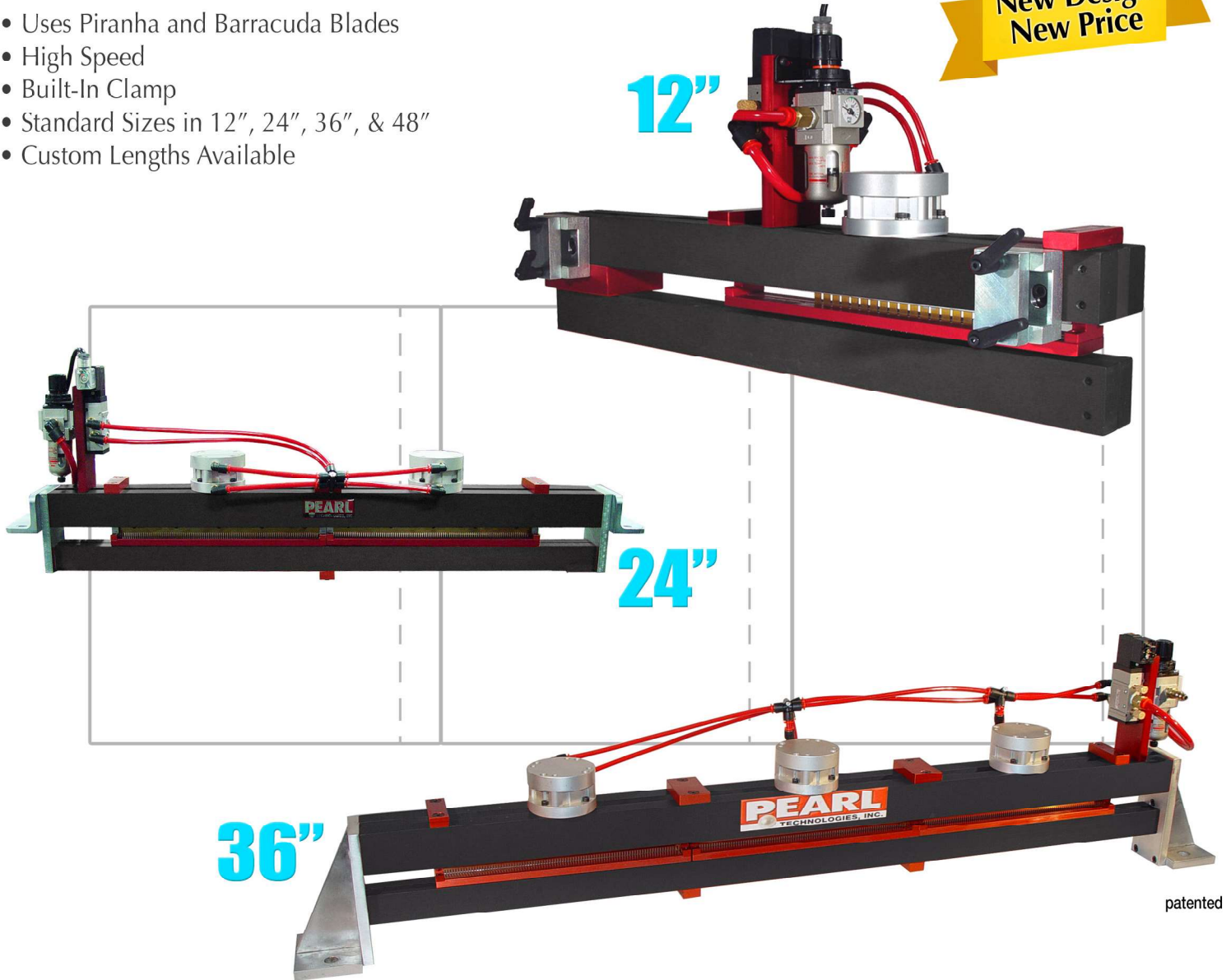

Stock Perf Blades

- Tru-Kote for Long-life

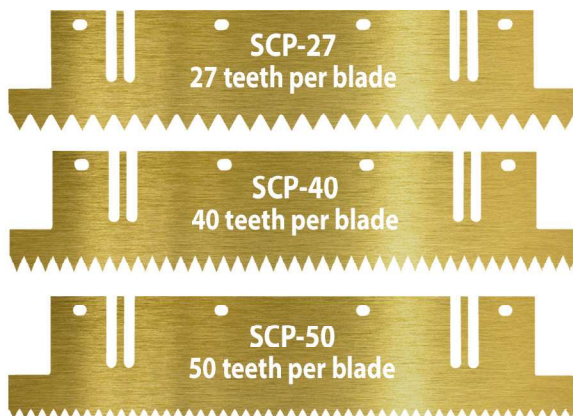

In-line Rotary Perf Attachment



- Heads & Dies Utilize Simple Built-in Pin Alignment System
- Eliminates Perf Scoring
- Variable Perf & Land "On-the-Fly"
- Long-life Blades
- Will Not Tear Film

We build custom perf attachments for unique applications. If your customer requests it, we'll make it for you!

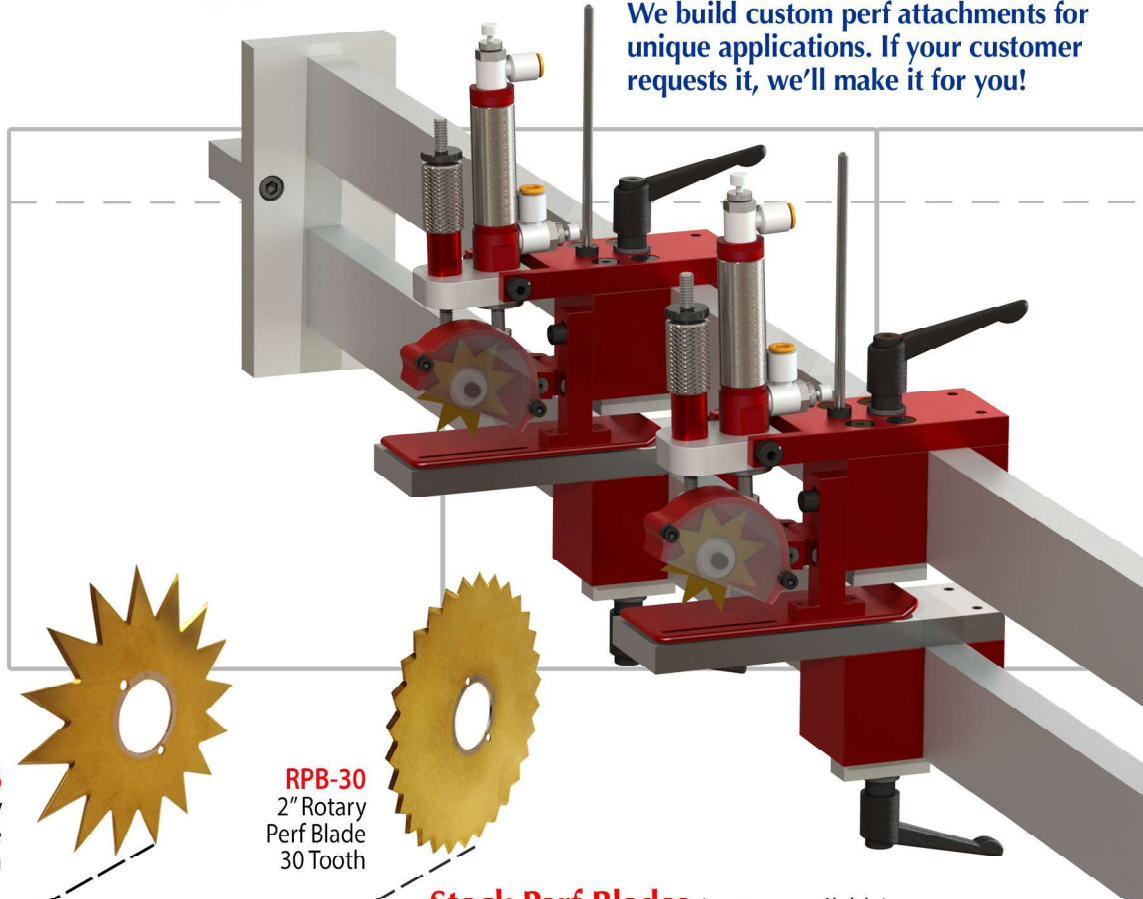
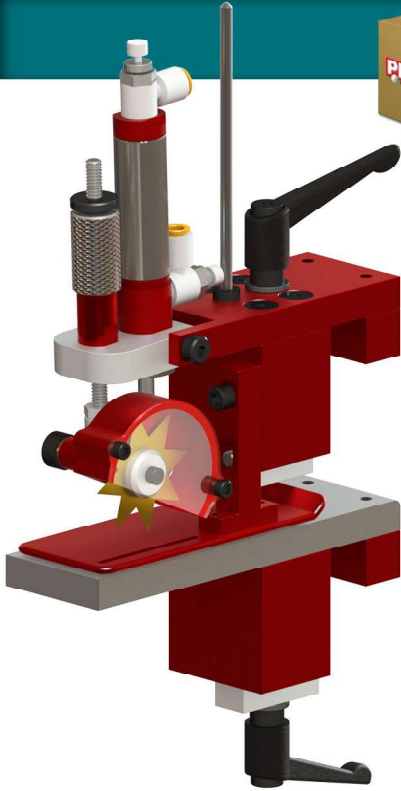

Rotary perfs are film driven and have the unique ability to vary the depth of the blade, translating into variable perf tear without changing blades.

RPB-8
2" Rotary Perf Blade
8 Tooth



RPB-16
2" Rotary Perf Blade
16 Tooth

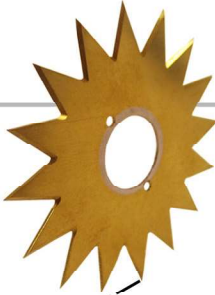

RPB-30
2" Rotary Perf Blade
30 Tooth



Stock Perf Blades (custom available)
Vary land and perf with a single blade.

Custom Perf Blades

Custom Blade Shapes

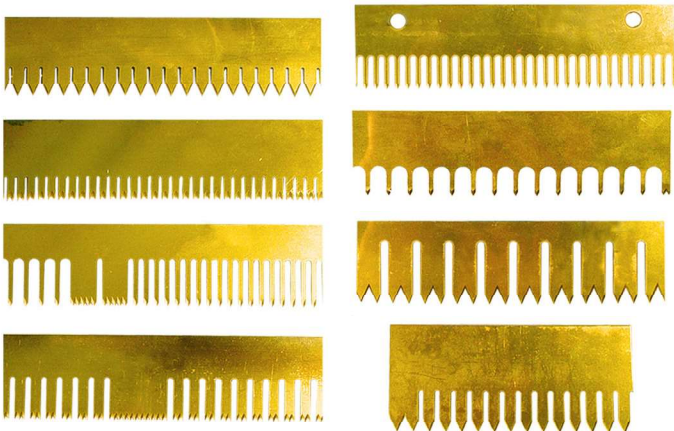

- Tru-Kote for Long-life Coating
- Exact Retrofits
- Custom Perf Patterns Specifications

Cut and Tie Terminology

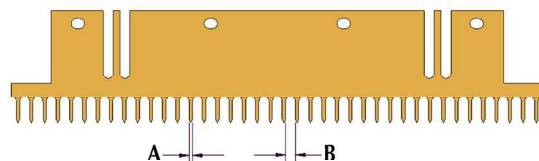

A) Cut and Perf: Where the material is cut (perforated)
B) Tie and Land: Where the material is uncut

Slit & Pin Vent Attachments

- Web Driven
- Custom Designs
- Unique Applications

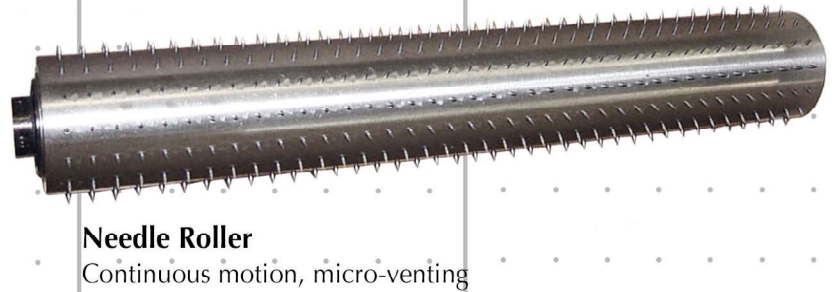
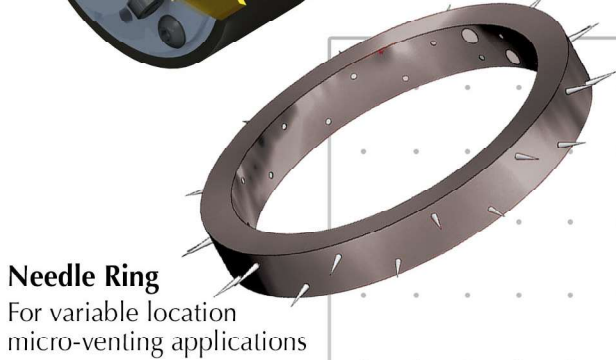
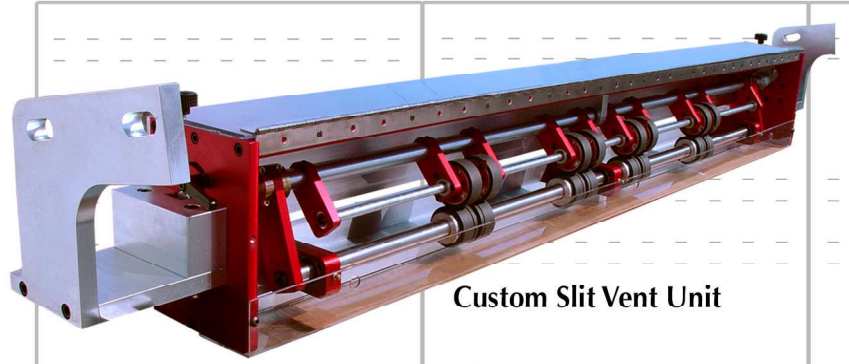
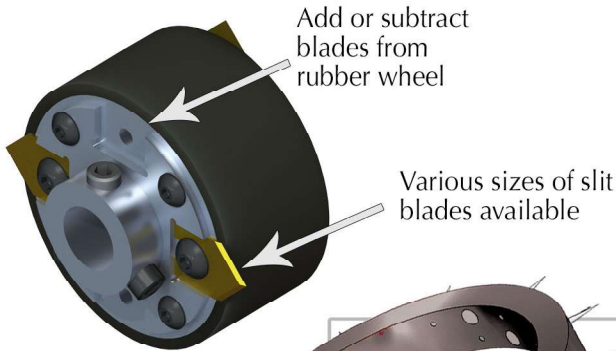

Vent Punches

2
PIECE

Combine with UNIV adapters on page 7

Butterfly Punch

Punch Size	Part Number
1/8"	SCB-18/1
3/16"	SCB-316/1
1/4"	SCB-14/1
5/16"	SCB-516/1
3/8"	SCB-38/1
7/16"	SCB-716/1
1/2"	SCB-12/1
1/2" Shark	SCB-12S/1

Pin Punch

Punch Size	Part Number
1/16"	SCP-116/1
3/32"	SCP-332/1
1/8"	SCP-18/1

"X" Cut Punch

Punch Size	Part Number
1/8"	SCX-18P/1
3/16"	SCX-316P/1
1/4"	SCX-14P/1 SCX-14B/1
5/16"	SCX-516P/1
3/8"	SCX-38P/1 SCX-38B/1 SCX-38P/114
7/16"	SCX-716P/1
1/2"	SCX-12P/1 SCX-12B/1

Square Punch

Punch Size	Part Number
1/8"	SCQ-18/1
1/4"	SCQ-14/1

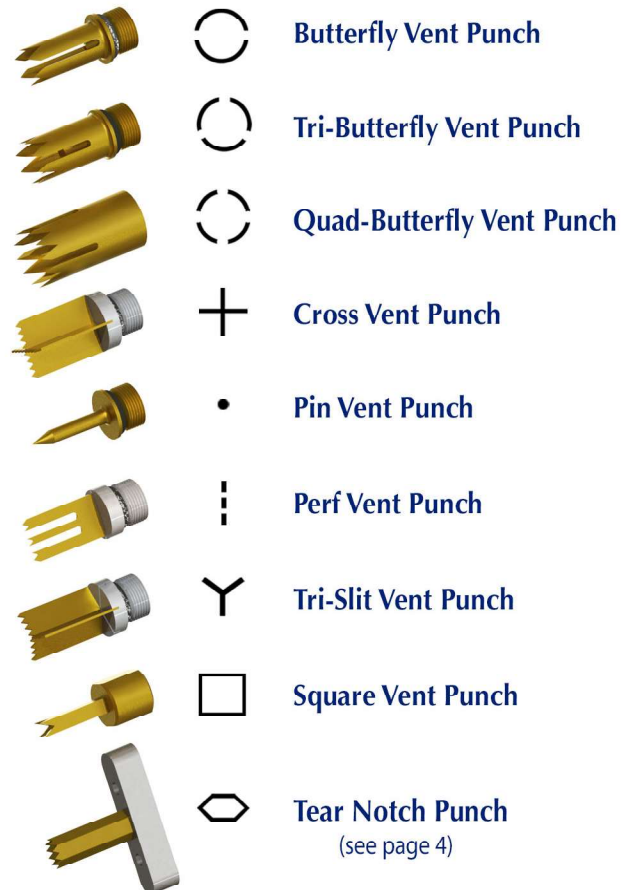

Vent Punching Attachments



Simple, single unit with manual Machine Direction (MD) adjustment.

- Tool-less Adjustment
- Built-in Strippers
- Diameters Ranging from 0.30 - 0.500"
- Custom Carriages

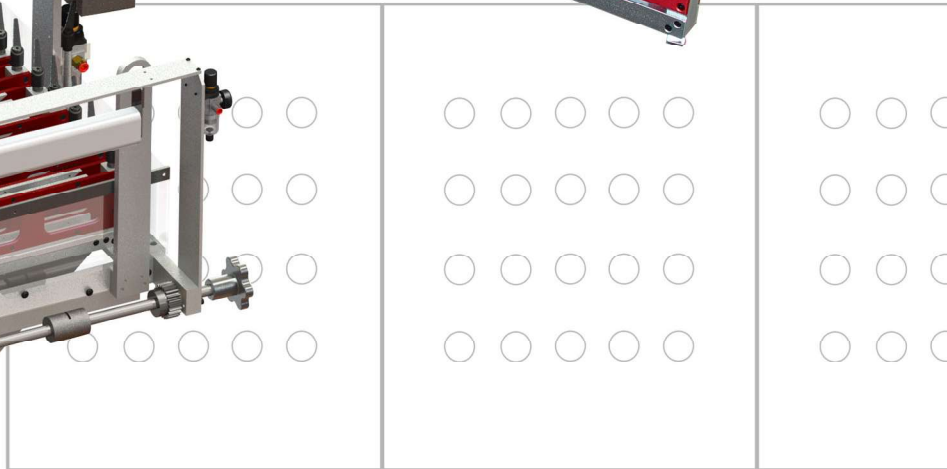
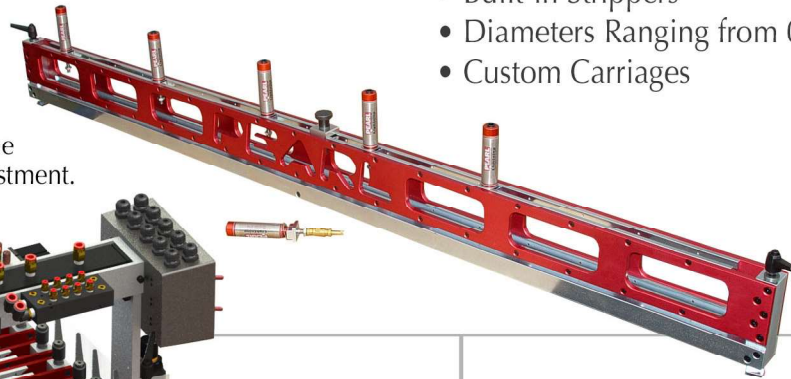
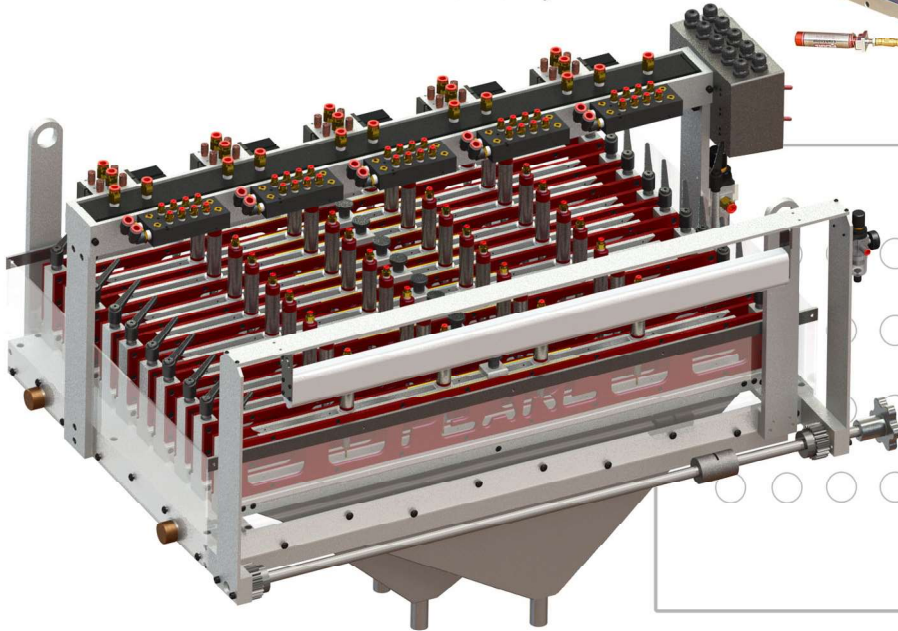

Vent Punches

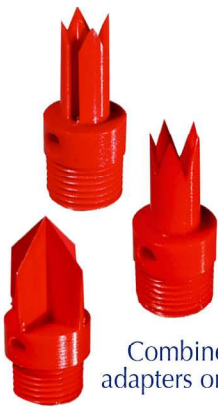

2
PIECE

Combine with adapters on page 8

Plastic Butterfly Punch

Punch Size	Part Number
1/4"	PCB-14
3/8"	PCB-38 PCB-38M
7/16"	PCB-716
1/2"	PCB-12
9/16"	PCB-916

Plastic Round Punch

Punch Size	Part Number
1/8"	PCR-18
1/4"	PCR-14 PCHM-14
3/8"	PCR-38 PCR-38A
7/16"	PCR-716 PCR-716A
1/2"	PCR-12 PCR-12A PCHM-12

Plastic "X" Cut Punch

Punch Size	Part Number
1/8"	PCX-18
1/4"	PCX-14
3/8"	PCX-38
7/16"	PCX-716
1/2"	PCX-12

- One or Two Piece Design
- Custom Sizes & Lengths Available
- English or Metric

One Piece Butterfly

Punch Size	Part Number
1/4"	SCB-14-PA/2
5/16"	SCB-516-PA/2
3/8"	SCB-38-PA/2
3MM	SCB-3MM-PA/2
4MM	SCB-4MM-PA/2
5MM	SCB-5MM-PA/2
6MM	SCB-6MM-PA/2

1
PIECE

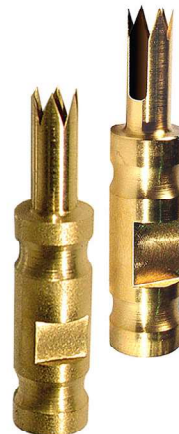

One Piece Cross Vent

Punch Size	Part Number
3/8"	SCX-38-PA/2

" = inches, HR = half moon, A = air sponge, M = single slot

Slitter Blades & Safety Cutters

The Best Slitters for Your Toughest Applications

Custom sizes & coatings available upon request



SS-3R Double edge w/safety corner
size: 3/4" x 2-1/4"
thickness: .015 inches



SS-3 Double edged coated blades
size: 3/4" x 2-1/4"
thickness: .015 inches



SS-3HD Double edged coated blades
size: 3/4" x 2-1/4"
thickness: .017 inches



SS-6 Double edged coated blades
size: 43 mm x 22.2 mm
thickness: .0085 inches



SS-1 size: 7/16" x 1-7/8"
thickness: .020 inches



SS-1C size: 7/16" x 1-7/8"
thickness: .020 inches



SS-1G size: 3/8" x 1-3/4"
thickness: .020 inches



SS-1M size: 1/2" x 1-7/8"
thickness: .020 inches



SS-1MC size: 1/2" x 1-7/8"
thickness: .020 inches



SS-1R size: 7/16" x 1-13/16"
thickness: .025 inches



SS-1RC size: 7/16" x 1-13/16"
thickness: .025 inches



SS-2 size: 13/16" x 1-7/8"
thickness: .020 inches



SS-2C size: 13/16" x 1-7/8"
thickness: .020 inches



SS-4 Single edge "injector"
size: 5/16" x 1-1/2"
thickness: .010 inches



PS-1 size: 7/16" x 1-7/8"



PS-2 size: 13/16" x 1-7/8"



PS-3 Double edged
size: 3/4" x 2"



PK-1 Safety cutter

PK-1S 100 replacement blades for PK-1 and PK-2



PK-2 Safety cutter

Cut film and tape, not fingers!

Slitting Attachments

- Infinite TD Adjustment
- Tool-less blade change
- 1" square mount

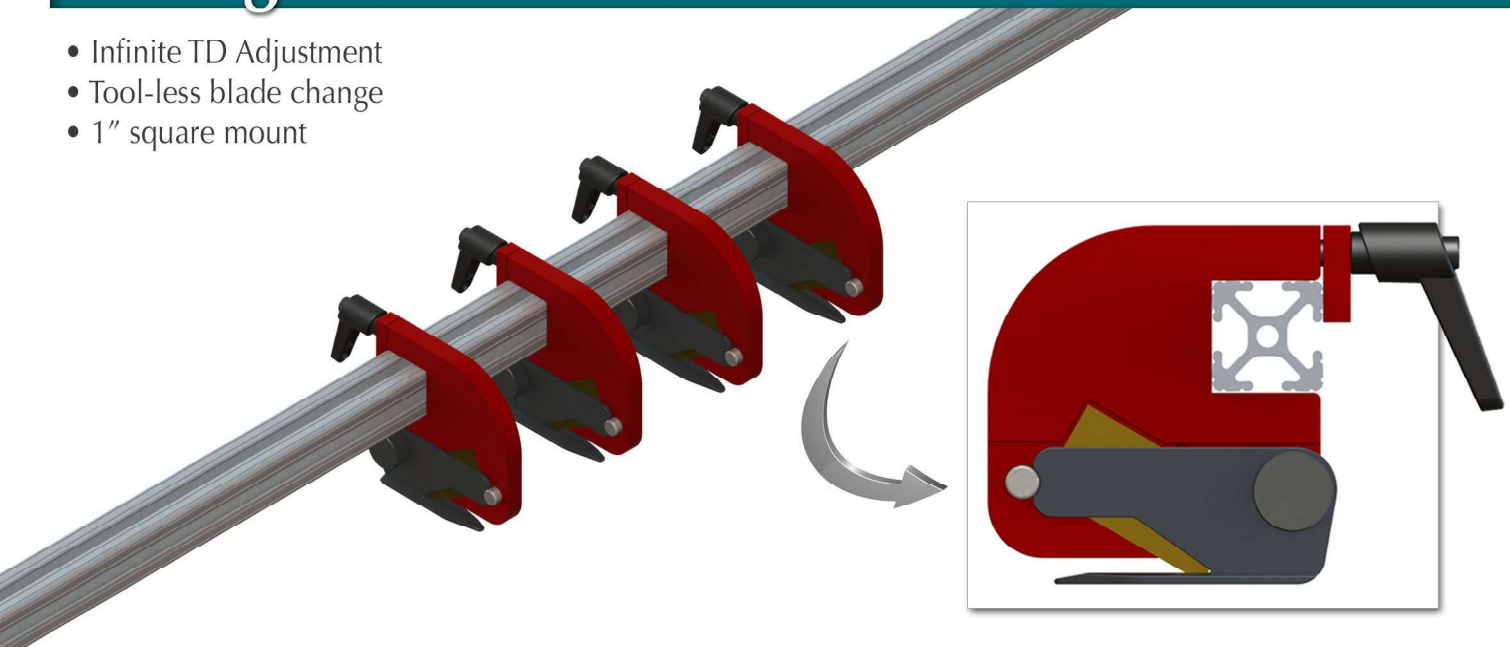

Cross Web Oscillating Slitter

**Retrofits Available
Upon Request**

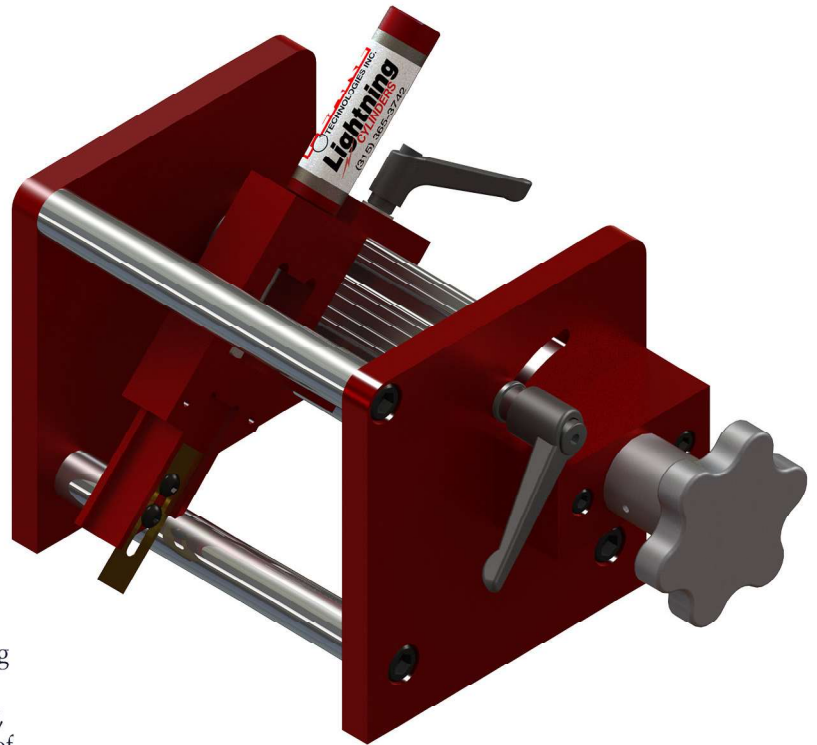
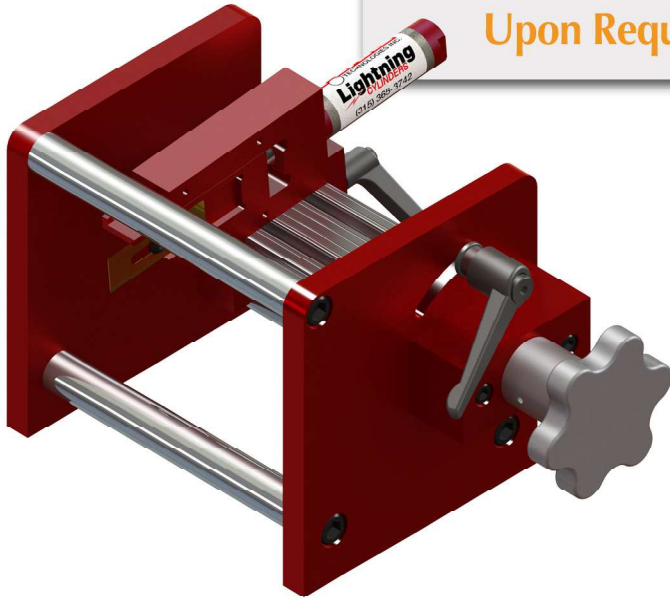

- Moving Slitter Blade for Exceptional Life
- Four Different Blade Wear Positions
- Infinite TD Adjustment
- Fine TD Adjustment
- Heads can be Rotated Out of the Film
- Minimum 7/8" Center to Center
- Custom Built Cross Web Carriages

The oscillating slitter unit is designed to decrease blade wear issues commonly associated with traditional slitting systems. A blade can be placed in four different wear positions to even out the wear on its edges. Additionally, the blade's constant movement eliminates the pressure of stopping and starting.

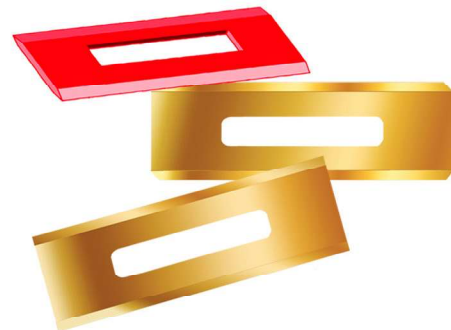
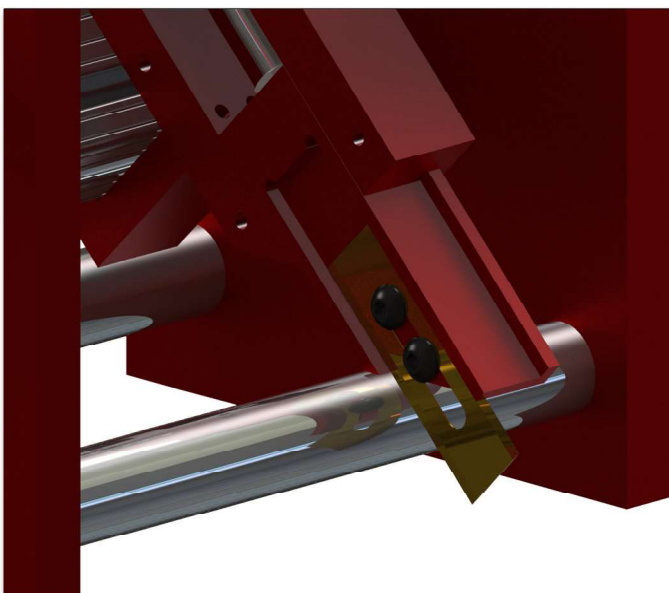

The Best Slitters for Your Toughest Applications

Custom sizes and coatings available upon request

See page 28 for more options!

Made to Order Spreader "D" Bars

- Wrinkle Free Webs
- Perfect for Thin Webs
- Will Not Scratch Web
- Zero Tension Required
- No Moving Parts
- Spread Lanes of Webs
- Self-cleaning
- Custom Built to Specifications



SM24
harder than
tool steel,
lower COF
than Teflon®
"liquid chill"



**Ultra-Low
COF cover**

*Available as inside mount,
top or bottom mount.*

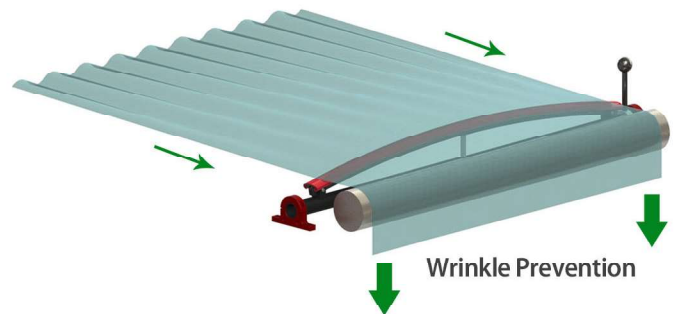
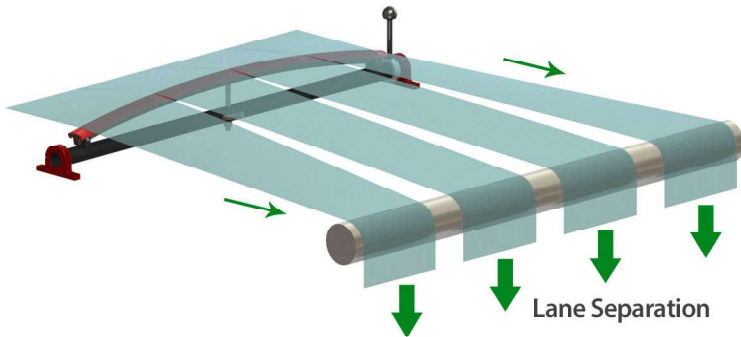

**Cantilever
Spreader (D-bar)**
For narrow web applications.
Can be chilled or heated.

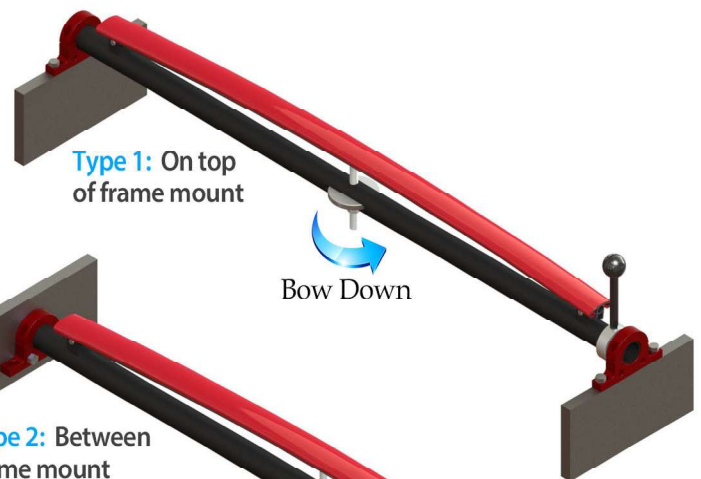

Folding Board

- Low COF* "V" Board Retrofits
- Improve Web Quality
- Replaceable Wear Covers
- Save Money & Downtime

SM24 or Ultra-Low COF Plastic

Retrofits available for any "V" boards. Save thousands of dollars worth of time and teflon tape on your "V" boards by switching to Pearl's design. Pearl will either offer retrofits or make new "V" boards for you.

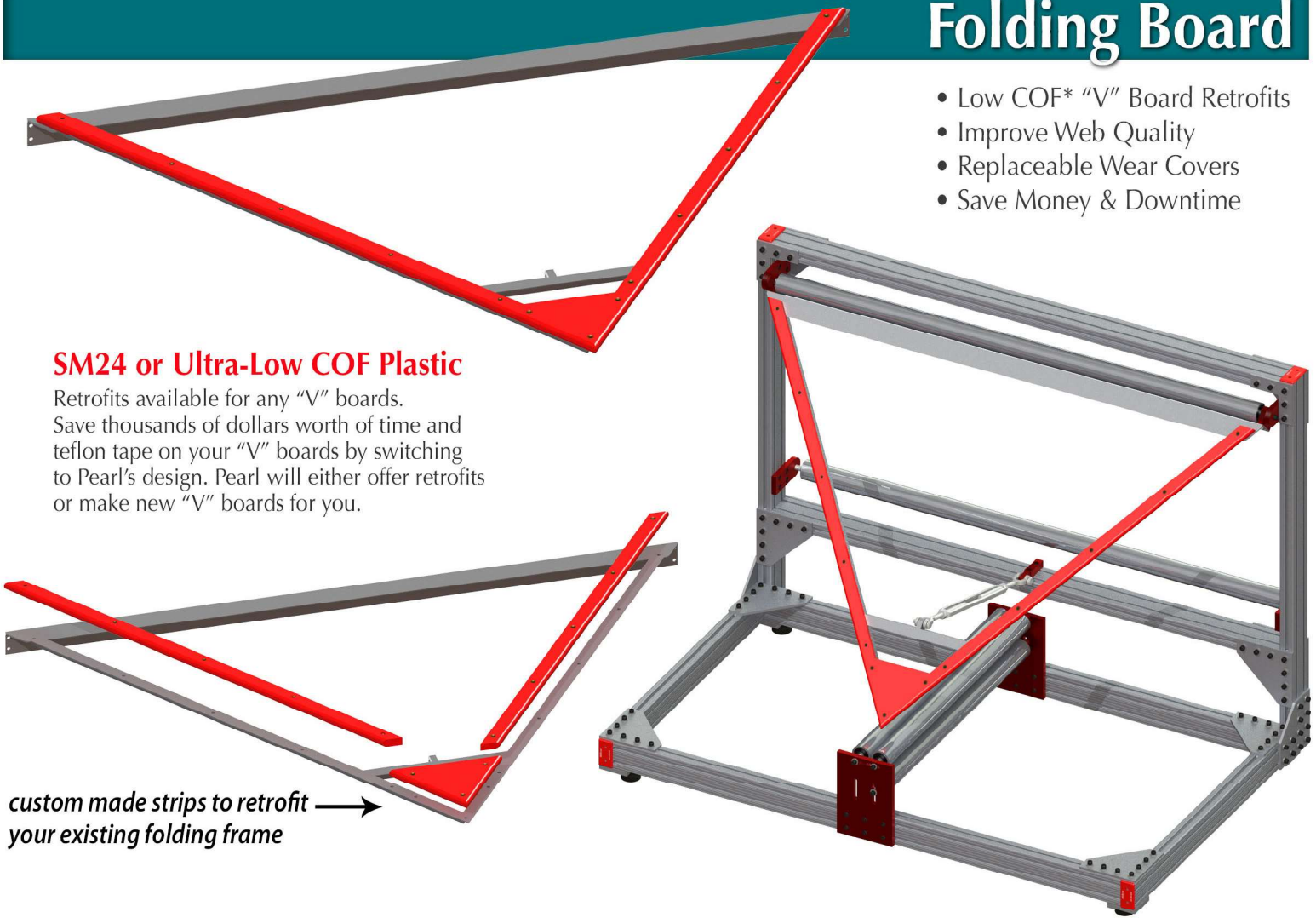

custom made strips to retrofit your existing folding frame →

Airless Turning Bar

- SM24 or Ultra-Low COF* Plastic
- Reduced Surface Contact
- Custom Made to Your Specifications



These bars have been successful in several applications. They are based on a very rigid lightweight aluminum extrusion that can be covered with our Ultra-Low COF plastic replaceable strips, or can be treated with our SM24 coating. All turning bars are custom built to fit your application.

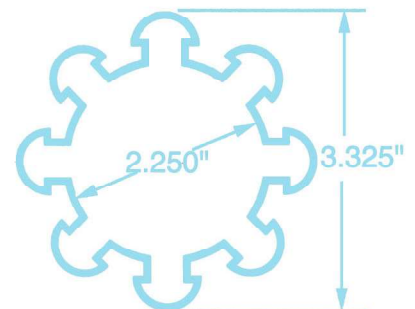

Cross Rail Carriages

- Available as Two-Rail or Four-Rail Mount
- Easy MD* Adjustment with Lock
- Designed & Built to Fit Your Frame
- Strong Support for Punch Units
- Optional Mounting for Air Equipment
- Custom Designs for Any Attachments

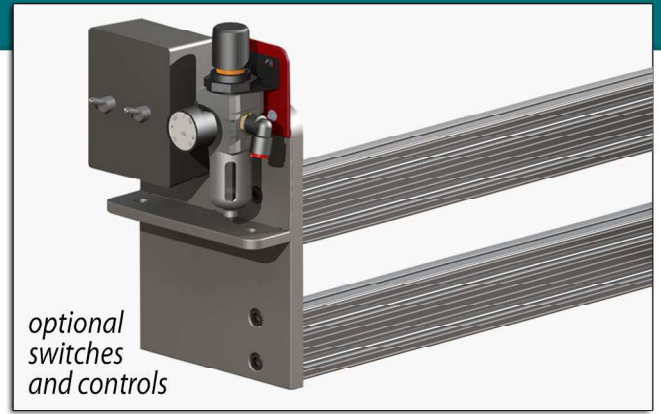

4-Rail
Manual adjust

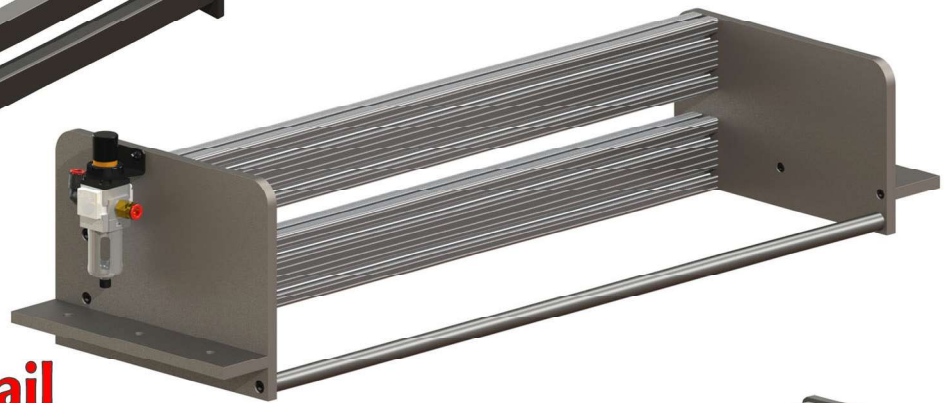

2-Rail
Manual Adjust



Multi-Vent Carriage

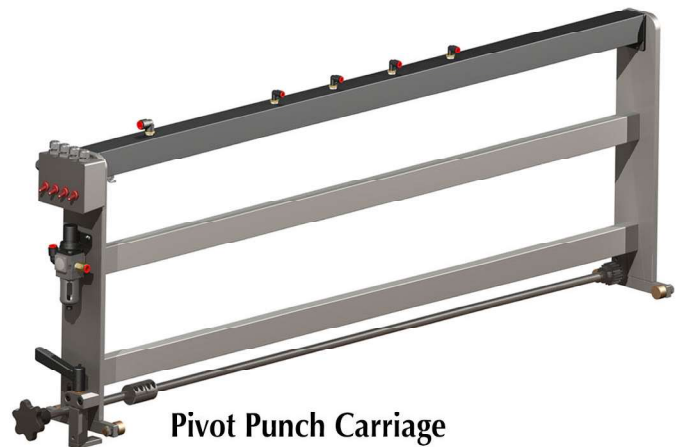

Pivot Punch Carriage

Custom Attachments

Can't find what you need?
We make custom units too!

- Any Application
- Quick Delivery
- Custom Designed to Your Specifications

Cross Web
Custom Shapes



Custom
Wickers



Folders

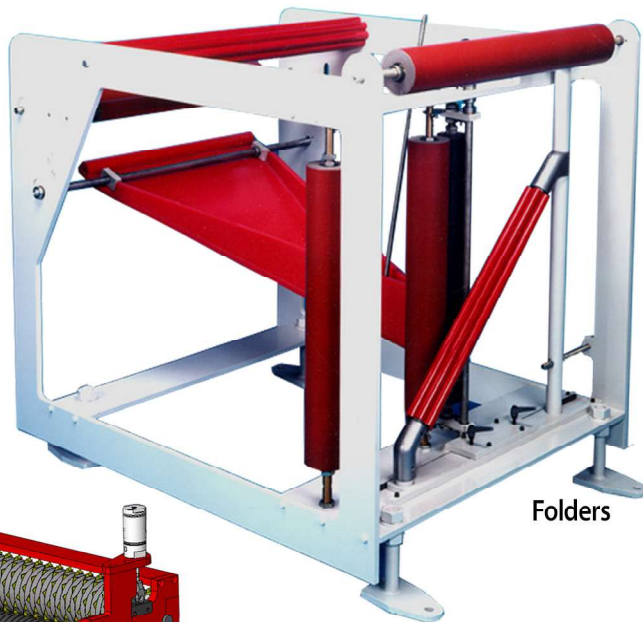

Roller-Vent

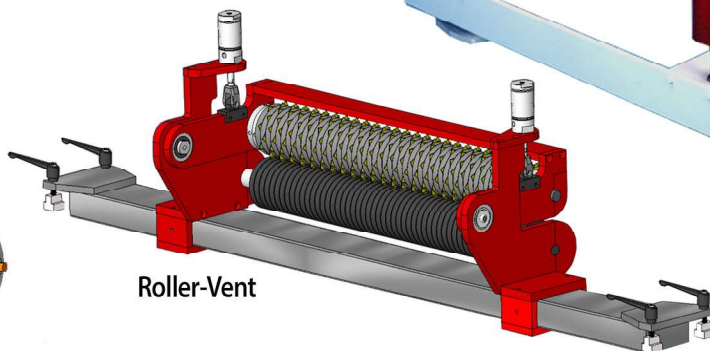

Multi-Vent Grape Bag Slits

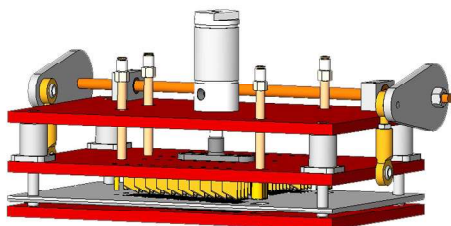

Side Guide
Large Cut-Out

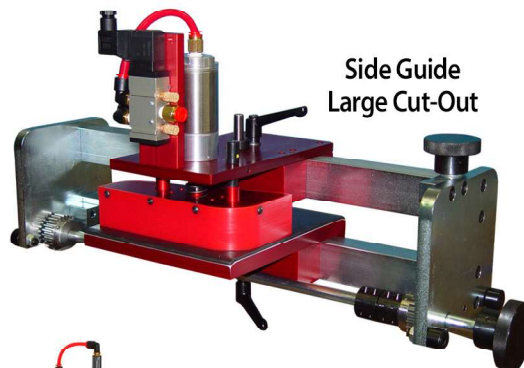

Vent
Slitter



Interchangeable
Multi-Punch Attachment

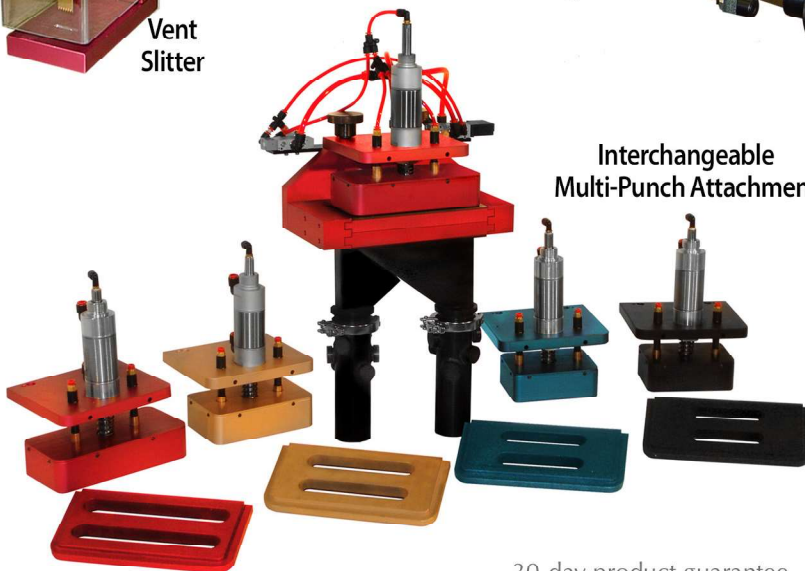

Multi-Head
Component
Punch Unit

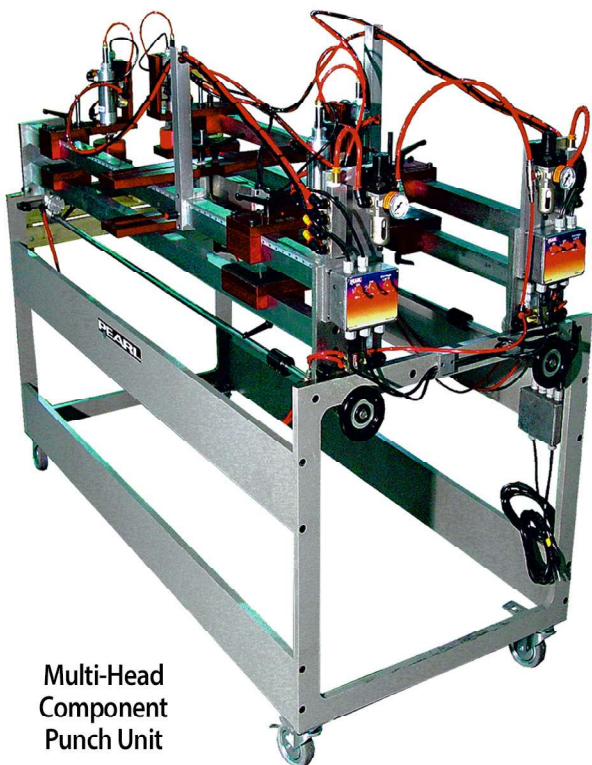

Custom Shape Punches

- High Quality Holes
- Any Shape, Any Size
- Various Tooth Options
- Different Coatings Available
- Ships 1-2 days
- Available With or Without Mounts

Call our sales team for a custom quote!



Pearl provides some of the sharpest, long-lasting punching on the market. Not sure which punch will work for your application? Call today to inquire about custom options.

Samples of shapes customers have requested.

Need a Quote?

In order for our Sales Team to better assist you, please specify the following:

1. How thick is your film/material?
2. How many layers are you punching?
3. Is your film continuous motion or intermittent?
4. What size and shape hole are you looking for?
5. What are your mounting requirements (threads, hole, overall length, cut and tie, tear strength)?
6. Do you have any special requirements?

Application Lab

- Side-by-side Analysis on Different Punch Attachments
- Pre-testing of Customer Supplied Film or Samples
- Trials for Both Continuous or Intermittent Applications

Pearl's new Application Lab allows pre-testing of customer material or samples on lab equipment. Send a sample and Pearl will recommend the best punch attachment unit or punch for the application. Results will be shared, making your choice easy.

Call today to learn more about this testing option, which will save both time and money!



Not sure which unit or punch will get the job done? Test your film in our new Application Lab!

Online Part & Unit Catalog

Registered Users – [Sign In to see Prices and Order Online](#)

Search Catalog View Cart View RFQs Express Ordering

By Keyword Shipping Tax Terms

Shopping Cart [0 Items](#)

Quotes [0 Items](#)

All Categories

Click on a category to drill down.

Request Information



[Converting Products](#)
Revolutionizing the Converting Industry with Quality Product Solutions



[Extrusion Products](#)
Revolutionizing the Blown Film Industry with Quality Product Solutions

New Pearl Products

[New Products](#)
In continuing our growth, Pearl has added more products to our selection! These products are designed to fulfill a wide range of film and line enhancements for both extruding and converting applications.

- Quick and Easy “Keyword” or Item Lookup
- Request a Quote Online
- Submit Inquiries with Ease
- Users Remain Registered

As Pearl's success and growth continues, so does our service to our customers. We now offer an online catalog that lists our stocked parts as well as available punch attachment units. The option now exists to request quotes online. To see the Pearl online catalog, visit:

<http://pearlproductcatalog.pearltechinc.com>

Interested in learning more, call or email Pearl today and ask about the Online Catalog.

Just a phone call away!

1. PEARL TECHNOLOGIES INC. -- ph: 315-365-3742 • fax: 315-365-3433
 sales@pearltechinc.com • www.pearltechinc.com • Savannah, NY 13146

2. Advanced Packaging Technology (Pty) LTD
 ph: +27-21-555-2825
 gary@advancedpt.co.za
 South Africa

3. Allied Equipment & Supplies Limited
 ph: +64-9-8272049
 peter.stewart@alliednz.co.nz
 New Zealand

4. Caco Plastics, Inc.
 ph: 562-463-0325
 cacoinfo@aol.com
 California, USA

5. CH Remy & Bientfait
 ph: +31-715-614-747
 jkrouwel@xs4all.nl
 Netherlands

6. Falcon Plastics-Machinery
 ph: +45 4594 0600
 fax: +45 4582 1328
 falcon@falcon.dk
 Denmark, Germany, Scandinavia

7. Foda Makina Mumessillik San Ve Tic A.S.
 ph: +90 212 567 4990
 ph: +90 212 544 50 00-01
 fax: +90 212 612 71 60
 foda@foda.com.tr
 Turkey

8. Gold Tech Machinery PTE LTD
 ph: +65 6264 7660
 fax: +65 6339 1513
 lewis@gold-tech.com.sg
 Singapore

9. HIIRod Equipment Sales
 ph: 404-250-0073
 dhills@hirodequipment.com
 Georgia, USA

10. Hudson-Sharp Machine CO BVBA
 ph: +32-2-464-01-60
 dirk.vanmedegael@hudsonsharp.com
 Belgium

11. Hudson-Sharp Machine Company
 ph: +61-9764-2255
 mark.bampfield@hudsonsharp.com
 Australia

12. Mando
 ph: +48-509-054-661
 bugaj.ka@gmail.com
 Poland

13. MarquWardUnited
 ph: +55-16-4243-8232
 naiara.planas@hudsonsharp.com
 Brazil

14. Mecanica Tecnomaq S.A. DE C.V.
 ph: +52-55-5576-3931
 info@tecnomaq.com.mx
 Mexico

15. MGB Teknik
 ph: +468-590-94440
 goran.eriksson@mgb.se
 Sweden

16. Octaplas
 ph: +54-11-4661-0496
 francistrost@aol.com
 Argentina

17. Prema Sarl
 ph: +33-686-430-432
 contact@prema.fr
 France

18. Refomag
 ph: +43-1-532-7922 (Vienna, Austria)
 fax: +43-1-532-7921 (Vienna, Austria)
 anton.friedmann@refomag.net
 Austria, Czech Republic, Hungary, Israel, Portugal, Slovakia, Slovenia, Spain

19. Refomag
 ph & fax: +57-1-407-6951
 (Bogotá, Colombia)
 fax & voicemail: 1-603-994-2520 (USA)
 sonia.gonzalez@refomag.net
 Colombia, Ecuador, Venezuela, Central America, Dominican Republic

20. SCAE Europe Srl
 ph: +39-055-311873
 n.tonarelli@scae-europe.it
 Italy

21. SVT/Schmidt Verpackungstechnik GmbH & Co.
 ph: +49-5405-80580
 office@schmidt-verpackungstechnik.de
 Germany

22. Swallow Machinery Ltd.
 ph: +44-148-485-0690
 swallowmachinery@btconnect.com
 England

23. Thomas This AS
 ph: +47-3254-8450
 pah@this.no
 Norway

Vanguard Steel Ltd.
 24. ph: 905-821-1100
 ead@vanguardsteel.com
 Mississauga, ON Canada

25. ph: 604-294-3191
 vancouver@vanguardsteel.com
 Burnaby, BC Canada

26. ph: 204-694-2259
 winnipeg@vanguardsteel.com
 Winnipeg, MB Canada

27. ph: 780-466-1115
 edmonton@vanguardsteel.com
 Edmonton, AB Canada

28. ph: 514-685-1515
 banfill@vanguardsteel.com
 Dorval, QC Canada

29. XL Plastics
 ph: +91-265-263-8125
 info@xlplastics.com
 India

30. Lambang Pasti Sdn. Bdh.
 ph: +60 19 5432 358
 heinz.bongers@lambangpasti.com
 Malaysia

